



**CITY OF HILLSBORO UTILITIES COMMISSION
SPECIAL MEETING AGENDA
Friday, January 26, 2018**

1:00 PM

Conference Room 333

Public Meeting

150 E. Main Street

Assistive Listening Devices (ALD) and sign language interpreters are available, at no cost, and can be scheduled for this meeting. Please provide at least 72 hours notice prior to the meeting. To obtain these services, call (503) 681-6100 or TTY (503) 681-6284.

ALL TESTIMONY IS ELECTRONICALLY RECORDED.

Call to order at 1:00 pm.

CALL TO ORDER

1. NEW BUSINESS

- A. Consider forwarding a recommendation to City Council for approval of the Willamette Intake Facilities IGA. *Staff Report – Kevin Hanway and Niki Iverson*

2. ADVICE/INFORMATION ITEMS

- A. The next regular Utilities Commission meeting is scheduled for 1:30 p.m. on February 13, 2018, at the Civic Center in Room C207.
- B. The next regular JWC and BRJOC meetings are scheduled on Friday, April 13, 2018, at the Civic Center. The BRJOC meeting will be held at 12:30 p.m. in Room 113B with the JWC meeting immediately following.



STAFF REPORT

To: Utilities Commission

From: Kevin Hanway, Water Department Director

Date: January 26, 2018

Re: Agenda Item 1A - Consider forwarding recommendation to City Council to adopt ordinance approving Willamette Intake Facilities Commission Intergovernmental Agreement

Staff Recommendation:

Approve a recommendation to City Council that it adopt ordinance approving Willamette Intake Facilities Commission Intergovernmental Agreement, and designate John Godsey as the Hillsboro representative to the Board, and David Judah as alternate.

Cost:

Hillsboro's estimated share of the first year (FY 2018-19) administrative costs for the WIF Commission is approximately \$30,000.

Attachments:

1. Willamette Intake Facilities Commission Intergovernmental Agreement and Exhibits.
2. Ordinance 6257 approving an intergovernmental agreement to establish the Willamette Intake Facilities Commission.

Background:

The City of Hillsboro and Tualatin Valley Water District (TVWD) have joined together to develop the Willamette Water Supply System (WWSS), a new regional water supply system. The new system will include modifications to and expansion of the existing intake facilities that are owned by TVWD, Wilsonville and Sherwood. The existing intake facilities already connect to pipes that deliver water from the intake facilities to the existing Willamette River Water Treatment Plant that supplies water to Wilsonville and Sherwood. WWSS will construct a separate raw water pipeline system that extends from the existing intake facilities to the new WWSS water treatment plant.

The Utilities Commission has approved an agreement to purchase a share of intake capacity ownership from TVWD. The cities of Tigard and Beaverton are also purchasing intake capacity ownership shares from TVWD.

The six municipal water suppliers who will own capacity shares in the intake facilities have completed negotiations on an intergovernmental agreement (IGA) to create a new governing

entity – the Willamette Intake Facilities Commission – to own, operate and manage the intake facilities. Negotiations on the IGA among the six parties began more than three years ago; for most of that duration the parties met on a twice-monthly basis. Niki Iverson, Hillsboro’s Water Resources Manager, with support from a facilitation consultant, facilitated the negotiation sessions and managed the ongoing process for drafting and revising the document and exhibits. Hillsboro was represented in the negotiations by Kevin Hanway (Water Director), Tacy Steele (Water Programs Manager), and Chris Crean (City Attorney office). Hillsboro’s representatives consulted regularly with the Utilities Commission and with the City Manager’s Office for guidance and confirmation on decisions made during negotiation sessions. The staff representatives for the other five parties also consulted regularly with their local decision makers.

A final draft of the Willamette Intake Facilities (WIF) Commission IGA was delivered to all of the parties in September 2017. The Utilities Commission reviewed and signed off on that final draft at its September 12, 2017, meeting. Similar authorizations have also been received from the other five parties. Based on those authorizations, the WIF IGA has been put into final form. A table at the end of this memo lists the key provisions of the IGA. The exhibits to the IGA have also been completed; they are listed on page 2 of the IGA and are attached at the end of the IGA.

The IGA is established under the statutory authority of ORS Ch. 190, which requires that the IGA be approved by ordinance of each of the parties to the agreement. The proposed ordinance is attached as an exhibit to this staff report.

Approval of the WIF Commission IGA will also allow the City Manager to execute two agreements that have already received the necessary Utilities Commission and City Council approvals: the Raw Water Pipeline Ground Lease agreement with the City of Wilsonville, and the Purchase and Sale Agreement with TVWD for purchase of intake capacity.

The Hillsboro City Council will need to appoint a representative and an alternate to the WIF Board. The Utilities Commission has expressed the intention to recommend John Godsey as the representative and David Judah as the alternate.

The proposed effective date for the WIF Commission IGA is April 6, 2018. After the effective date, the WIF Commission Board will hold its initial meeting, at which it will elect officers, and approve a work plan and budget for FY 2018-19.

Key Policy Points – Willamette Intake Facilities Commission IGA

Purpose	Ownership, governance and operation of intake facilities. (Raw water pumps and pipelines, water treatment plants and transmission pipelines are handled under separate IGAs.)		
Parties and Ownership Interests	Only municipal water providers may become Parties.		
	<i>Party</i>	<i>Capacity (million gallons per day)</i>	<i>Capacity %</i>
	Tualatin Valley Water District (TVWD)	59.1	39.40%
	City of Wilsonville	25.0	16.67%
	City of Sherwood	9.7	6.47%
	City of Hillsboro	36.2	24.13%
	City of Tigard	15.0	10.00%
	City of Beaverton	5.0	3.33%
	Total	150.0 MGD	100%
Assets	Intake infrastructure facilities: intake screens, intake pipeline, caisson/raw water holding tank, seismic reinforcement structures. See IGA Exhibit 2.		
Governing Body	A 6-member Board, consisting of one member and one alternate appointed by each party's governing body, will meet quarterly and have full governing authority.		
Voting	Action requires affirmative vote of supermajority (5 of 6); except a unanimous vote (6 of 6) is required for three actions: approval of a new party to join IGA, issuance of debt by the Commission, and amendment of the IGA.		
Managing Agency	A Managing Agency will perform day-to-day management and will provide support for the Commission's committee and Board functions. TVWD is designated as the initial Managing Agency through 6/30/2032 (covers the period during design and construction of the new Willamette Water Supply System improvements, plus one 6-year term). After completion of initial Managing Agency term, the term of Managing Agency appointment is 6 years. Wilsonville will continue to maintain responsibility for operation and maintenance of the existing intake facilities through 6/30/2026; then responsibility for intake facility operations will also pass to TVWD as Managing Agency.		
Committees	Parties provide technical, budget, and policy input to the Managing Agency and Board through Operations, Finance, and Management Committees. See IGA Exhibit 6.		
Cost Allocations	Capital Improvements and Facilities Maintenance: costs allocated based on ownership percentages. Other costs (such as administration): allocated 75% based on ownership percentages, 25% in equal shares.		
Utilizing Intake Capacity	A party's draw of water through the intake facility cannot exceed its ownership capacity. If other parties own intake capacity greater than their need, those parties may choose to make that excess capacity available to be leased by other parties who are seeking access to additional capacity. A party is subject to penalties if it utilizes more than its share of owned and leased intake capacity.		

ORDINANCE NO. 6257

AN ORDINANCE APPROVING AN INTERGOVERNMENTAL AGREEMENT TO ESTABLISH THE WILLAMETTE INTAKE FACILITIES COMMISSION.

WHEREAS, the above-entitled matter came before the City of Hillsboro (City) City Council at its regular meeting on February 20, 2018; and,

WHEREAS, the City previously entered into the Agreement for Design and Construction of the Willamette Water Supply Program (Agreement) dated June 16, 2015, with the Tualatin Valley Water District (TVWD) for the design, financing and construction of the Willamette Water Supply System; and,

WHEREAS, the City, TVWD and other cities either own, or intend to acquire, interests in the intake facilities that provide raw water for the Willamette River Water Treatment Plant and the Willamette Water Supply System; and,

WHEREAS, pursuant to ORS 190, the Cities of Hillsboro, Wilsonville, Sherwood, Beaverton, Tigard and TVWD jointly negotiated an intergovernmental agreement (IGA) to create an entity known as the Willamette Intake Facilities (WIF) Commission; and,

WHEREAS, the purpose of the WIF Commission is to own and to oversee operations and management of the shared intake facilities; and,

WHEREAS, the intergovernmental agreement becomes effective on April 6, 2018; and,

WHEREAS, the WIF Commission IGA was reviewed by the City of Hillsboro Utilities Commission on January 26, 2018, and forwarded to the City Council with a recommendation that it be approved; and,

WHEREAS, after reviewing the WIF Commission IGA, the City Council has determined that establishing and participating in the WIF Commission as described in the IGA is in the City's best interest; and,

WHEREAS, based on the foregoing, the City Council declares it is the City's intent to create the WIF Commission as described in the intergovernmental agreement.

NOW, THEREFORE, THE CITY OF HILLSBORO ORDAINS AS FOLLOWS:

Section 1. The intergovernmental agreement, Exhibit A, is approved.

Section 2. The City Manager is authorized to execute the intergovernmental agreement on behalf of the City.

Section 3. The City Council shall appoint a person and an alternate to serve on the WIF Commission. The City's representative is authorized to approve modifications to the intergovernmental agreement exhibits without further review by the City Council.

Section 4. This ordinance shall be effective from and after 30 days following its passage and approval by the Mayor.

First approval of the Council on this 6th day of February, 2018.

Second approval and adoption by the Council on this 20th day of February, 2018.

Approved by the Mayor this 20th day of February, 2018.

Steve Callaway, Mayor

ATTEST: _____
Amber Ames, City Recorder

Willamette Intake Facilities Intergovernmental Agreement

**EFFECTIVE DATE
APRIL 6, 2018**

**BY AND AMONG
TUALATIN VALLEY WATER DISTRICT
CITY OF WILSONVILLE
CITY OF SHERWOOD
CITY OF HILLSBORO
CITY OF TIGARD AND
CITY OF BEAVERTON**

TABLE OF CONTENTS

EXHIBIT LIST	2
RECITALS	3
AGREEMENT	8
2. Definitions	8
3. Commission	13
4. Board of Commissioners	13
5. Managing Agency	16
6. Management, Operations, Finance, and Other Committees	20
7. Financial Management	21
8. Intake Facilities Ownership and Easement	26
9. Water Rights	26
11. Operations Plan	28
12. Curtailment Plan and Emergency Response and Management Plan	29
13. Right of First Offer	29
14. Leasing	30
15. Overuse	33
16. Remedies for Overuse	34
17. Expansion and Capital Improvements	35
18. Sale of Water to Non-Party	37
19. Withdrawal and Sale of Interest	37
20. Admission of New Municipal Parties	41
21. Indemnity	43
22. Default	44
23. Remedies	46
24. Default by the Managing Agency	48
25. Dispute Resolution	50
26. Dissolution	52
27. General Provisions	53

EXHIBIT LIST

Exhibit No.	Title
1	Willamette Intake Facilities Easement Agreement (“Easement”)
2	Willamette Intake Facilities Preliminary Design Drawings and Layout
3	Willamette Intake Facilities Capacity Ownership Allocations
4	Real Property
5	Water Rights Authorized for Use at the Willamette Intake Facilities (“Water Rights”)
6	Willamette Intake Facilities Organizational Structure
7	Willamette Intake Facilities Initial Management Plan
8	Willamette Intake Facilities Budget Calendar
9	Willamette Intake Facilities Interim Financials Procedures
10	Willamette Intake Facilities Lease Formulas and Sample Lease
11	Willamette Intake Facilities Improvements Cost Allocation Summary
12	Willamette Intake Facilities Insurance Requirements and Limits
13	Existing Agreements

Willamette Intake Facilities Intergovernmental Agreement

This Willamette Intake Facilities Intergovernmental Agreement (“Agreement”) for the ownership, management and operation of the Willamette Intake Facilities (“Intake Facilities”) is entered into between Tualatin Valley Water District (“TVWD”), a domestic water supply district organized under ORS Chapter 264; the City of Wilsonville (“Wilsonville”), a municipal corporation; the City of Sherwood (“Sherwood”), a municipal corporation; the City of Hillsboro (“Hillsboro”) a municipal corporation; the City of Tigard (“Tigard”), a municipal corporation; and the City of Beaverton (“Beaverton”), a municipal corporation; all of which are local governments authorized to own, operate and maintain municipal water supply systems. The cities and TVWD may be referred to herein individually as a “Party” or jointly as “Parties.”

RECITALS

WHEREAS, TVWD is a domestic water supply district under ORS 264, which distributes potable water to its respective water system Users;

WHEREAS, Wilsonville operates a municipal water supply utility under ORS 225, which distributes potable water to its respective water system Users;

WHEREAS, Sherwood operates a municipal water supply utility under ORS 225, which distributes potable water to its respective water system Users;

WHEREAS, Hillsboro operates a municipal water supply utility under ORS 225, which distributes potable water to its respective water system Users;

WHEREAS, Tigard operates a municipal water supply utility under ORS 225, which distributes potable water to its respective water system Users;

WHEREAS, Beaverton operates a municipal water supply utility under ORS 225, which distributes potable water to its respective water system Users;

WHEREAS, TVWD and Wilsonville entered into the *Agreement Regarding Water Treatment Plant Design, Construction, Operation and Property Ownership*, dated July 6, 2000 (“2000 Master Agreement”), and the *Accord Agreement* dated June 19, 2001 (“Accord”), to construct and operate intake facilities, pumps, a water treatment plant, and certain transmission facilities upon jointly owned real property (“Willamette River Water Treatment Plant”) for the purpose of supplying potable water to Wilsonville and providing a future water supply for TVWD;

WHEREAS, TVWD and Wilsonville entered into the *First Amendment to Agreement Regarding Water Treatment Plant Design, Construction, Operation, and Property Ownership*, dated _____, 2018, which modified the above agreement to reflect a change in direction and the rights and obligations between TVWD and Wilsonville;

WHEREAS, TVWD and Wilsonville have also entered into an Operation and Maintenance Contract with Veolia Water North America-West LLC, dated July 1, 2012, as amended, which pertains to the Willamette River Water Treatment Plant and the Intake Facilities;

WHEREAS, in April 2002, Wilsonville and TVWD completed construction of the intake and the Willamette River Water Treatment Plant facilities, including the fish screens, intake pipeline, a raw water pump station, raw water transmission line, the treatment plant and related appurtenances including electrical facilities;

WHEREAS, TVWD and Sherwood entered into an Agreement on December 27, 2006 (“Sherwood TVWD WRWTP Agreement”) for the purchase and sale of five million gallons per day (“MGD”) of capacity in the Intake Facilities, pump station, treatment plant, and certain transmission facilities for the purpose of supplying potable water to Sherwood;

WHEREAS, on October 15, 2008, TVWD Sherwood, Tigard, and Tualatin entered into the *First Restated Intergovernmental Cooperative Agreement Continuing the Willamette River Water*

Coalition” (“WRWC Agreement”) to jointly hold a water right permit for future use of Willamette River water and to plan for regional water supply facilities that would meet future needs;

WHEREAS, Hillsboro and TVWD entered into the *Agreement for Design and Construction of the Willamette Water Supply Program* (“WWSP Agreement”) on June 16, 2015 to permit, design, and construct a water supply system including intake and transmission facilities, a water treatment plant, and reservoir facilities (“Willamette Water Supply System”) to provide additional potable water to Hillsboro and TVWD and provide for system redundancy and reliability;

WHEREAS, TVWD, Hillsboro, and Wilsonville entered into a *Ground Lease for the Raw Water Pipeline*, dated _____, 2018, and an *Easement for Raw Water Pipe*, dated _____, 2018, that will allow the Intake Facilities to connect to a raw water pipeline located in and along Wilsonville right-of-way and lands owned or to be acquired by Wilsonville and TVWD;

WHEREAS, the Parties hold or may hold certain storage, release and surface water rights on the Willamette River and its tributaries (“Water Rights”) for the purpose of providing water to the Treatment Plant Facilities for ultimate delivery to their respective water system Users;

WHEREAS, the Intake Facilities provide a regional benefit and are the foundation of the other water system assets of the Parties.

WHEREAS, the Parties except Wilsonville are in the process of acquiring a portion of TVWD’s excess capacity ownership interest in the Intake Facilities from TVWD and, with respect to those transfers, Wilsonville has agreed to waive its First Right of Offer pursuant to the *Agreement Regarding Water Treatment Plant Design, Construction, Operation, and Property Ownership*, dated July 6, 2000 (“2000 Master Agreement”) the *Accord Agreement*, dated June 19,

2001 (“Accord”), and the *First Amendment to Agreement Regarding Water Treatment Plant Design, Construction, Operation, and Property Ownership*, dated _____, 2018;

WHEREAS, Wilsonville already owns the Intake Facilities with TVWD, but is participating in expanding the screen to allow for additional 5 MGD capacity, among other rights, pursuant to the *City of Wilsonville and Tualatin Valley Water District Willamette Water Supply System Intake Facility Agreement*;

WHEREAS, the transfer, purchase and sale of a portion of TVWD’s excess capacity in the Intake Facilities to the Parties, except Wilsonville, are governed by the *Agreement(s) for Transfer, Purchase and Sale of Intake Facilities*, dated _____, 2018. TVWD’s transfer to Wilsonville is governed by the *City of Wilsonville and Tualatin Valley Water District Willamette Water Supply System Intake Facility Agreement*. A condition of any transfer by TVWD of existing Intake Facility capacity is the expansion of the Intake Facilities to an anticipated capacity of 150 MGD;

WHEREAS, the Parties each own and operate municipal water supply systems that provide essential service to their communities, including protection of public health, emergency fire suppression, and potable water supply to support viable community and economic activities, and the Intake Facilities are the foundation of those other water systems;

WHEREAS, the purpose of this Agreement is to set forth the terms for the joint ownership, operation and management of the Intake Facilities in a prudent, economic and efficient manner to provide water to the existing Willamette River Water Treatment Plant (“WRWTP”) and the anticipated Willamette Water Supply System Water Treatment Plant (“WSS WTP”), to preserve and protect the Parties’ Water Rights, to support the functioning of the Intake Facilities as the foundation of their water systems, and to support their commitment to watershed planning and management; and

WHEREAS, the Parties are authorized under ORS 190 to enter into an agreement for the performance of any or all functions and activities that the Parties, their officers, employees or agents have authority to perform, and to create this intergovernmental entity.

NOW, THEREFORE, in consideration of the mutual covenants and agreements contained herein, the Parties agree as follows:

AGREEMENT

Based on the foregoing Recitals and the mutual promises and obligations as set forth herein, and other good and fair consideration, the sufficiency of which is hereby acknowledged, the Parties agree to the following.

1. Effective Date

This Agreement is effective as of the 6th day of April, 2018.

2. Definitions

As used in this Agreement, the following terms when capitalized shall have the following meanings:

- 2.1. **Agreement** means this Willamette Intake Facilities Intergovernmental Agreement.
- 2.2. **Board** means the Board of Commissioners of the Willamette Intake Facilities Commission created by this Agreement, consisting of one elected or appointed official from each Party. Each Party will appoint one Board member and each Board member will have one equal vote.
- 2.3. **Capacity** means the instantaneous ability of various components of the Intake Facilities to deliver available water that does not exceed a Party's allocation, measured in million gallons per day, gallons per minute, cubic feet per second or other comparable measurement as set forth in the Operations Plan and consistent with generally accepted engineering and prudent utility operating practices.
- 2.4. **Capacity Expansion** means the expansion of the Intake Facilities through a capital improvement project.

- 2.5. **Commission** means the Willamette River Intake Facilities Commission, an ORS 190 entity formed under this Agreement whose Parties are TVWD, Wilsonville, Sherwood, Hillsboro, Tigard, and Beaverton.
- 2.6. **Curtailment Plan** means a plan developed and approved by the Board for curtailment of water service in accordance with OAR Chapter 690 Division 86 rules.
- 2.7. **Demand** means the amount of water used or projected to be used by a Party and imposed on the Intake Facilities to deliver water to be treated at a Water Treatment Plant where the Party owns capacity. The instantaneous measurement of Demand shall be defined in the Operations Plan as million gallons per day, gallons per minute, cubic feet per second, or other agreed measurement for the Intake Facilities.
- 2.8. **Easement** means the Intake Facilities Easement, attached as **Exhibit 1**.
- 2.9. **Emergency Response Plan** means a plan that outlines emergency procedures that are recommended for implementation by the Federal Emergency Management Agency and are consistent with the National Incident Management System in order to respond quickly and appropriately to an emergency event.
- 2.10. **Effective Date** means the date specified in Section 1.
- 2.11. **Facilities Modification** means a capital improvement to meet operational changes or upgrades in response to requirements of regulatory agencies, but that does not result in a Capacity Expansion.
- 2.12. **Finance Committee** means the committee with a representative appointed by each Party to act as provided in Section 6.3.
- 2.13. **Fiscal Year** means the time period July 1 through June 30.

- 2.14. **Intake Facilities** means existing, expanded, or upgraded Intake Facilities - used to withdraw and transmit water to the Parties at the agreed System Separation Point between the Willamette River Water Treatment Plant System and the Willamette Water Supply System Water Treatment Plant. The Intake Facilities include the fish screens, intake pipe, caisson, pump station building, and other jointly owned equipment leading up to the System Separation Point described in **Exhibit 2**, and the Intake Facilities Easement described in **Exhibit 1**.
- 2.15. **Lease** means the lease of Capacity in the Intake Facilities according to the terms and conditions of Section 14.
- 2.16. **Management Committee** means the committee with a representative appointed by each Party to act as provided in Section 6.1.
- 2.17. **Managing Agency** means the Party designated under Section 5 to manage the business affairs of the Commission and act in accordance with Section 5 and other provisions of this Agreement.
- 2.18. **Master Plan** means a plan that analyzes the performance, documents recommended upgrades, estimates water demand projections from the Parties, and updates the capital improvement plan of the Intake Facilities.
- 2.19. **Member** means a person appointed by a Party to serve on the Board.
- 2.20. **MGD** is an acronym for million gallons per day.
- 2.21. **Municipal Water Provider** means a city or special district, as defined by ORS 174.116, that supplies drinking water to the public.
- 2.22. **Non-Peak Season** means the period from November 1st through April 30th of any given year.

- 2.23. **Operations Committee** means the committee with a representative appointed by each Party to act as provided in Section 6.2.
- 2.24. **Operations Plan** means the plan that describes the operational protocols, communications, and coordination for the Intake Facilities with the Water Treatment Plants.
- 2.25. **Ownership** means the Capacity interest of a Party in the Intake Facilities, established following a financial investment in the Intake Facilities. The anticipated Capacity of each Party is set forth in **Exhibit 3**.
- 2.26. **Party or Parties** means the Municipal Water Providers that have Capacity ownership interest in the Intake Facilities and that comprise the Commission.
- 2.27. **Peak Season** means the period from May 1st through October 31st of any given year.
- 2.28. **Point of Diversion** means the geographic location from which water is diverted from the Willamette River using the Intake Facilities and put to beneficial use through the Water Treatment Plants and associated water systems.
- 2.29. **Real Property** means the real property upon which the Intake Facilities are located. The Real Property is described in **Exhibit 4** and is owned by TVWD and Wilsonville.
- 2.30. **Supermajority** means an affirmative vote from all except one of the Members of the Board eligible to vote.
- 2.31. **System Separation Point** means that point designated on **Exhibit 2** where the Intake Facilities terminate and the water from the caisson of the Intake Facilities is separated by the pumps into untreated water pipes conveying water to either the

WRWTP or WWSS WTP.

- 2.32. **Users** means any water system users or customers of a Party's water system including but not limited to residential, commercial and industrial uses as well as other units of local government with whom the Party has agreed to sell water.
- 2.33. **Water Rights** means those surface water registrations, permits (including storage and secondary), or certificates held by a Party, the WRWC, or the Commission as registered with the State of Oregon Water Resources Department, which allow for diversion of water from the Willamette River at the existing Intake Facilities Point of Diversion to deliver water to the Party's respective Water Treatment Plant. The Water Rights are more fully described in **Exhibit 5**.
- 2.34. **Water Treatment Plant** refers to either the WRWTP or the WWSS WTP.
- 2.35. **Willamette River Water Coalition ("WRWC")** means the ORS 190 entity currently consisting of TVWD and Sherwood, Tigard, and Tualatin.
- 2.36. **Willamette River Water Treatment Plant ("WRWTP")** means the Water Treatment Plant located near the Intake Facilities currently serving potable water to Wilsonville, Sherwood, and other potential Parties.
- 2.37. **Willamette Water Supply System ("WWSS")** means the water supply system infrastructure facilities including the raw water pipeline, water treatment plant, finished water pipeline(s), finished water storage, and related facilities that serve potable water to TVWD, Hillsboro, and other potential Parties.
- 2.38. **Willamette Water Supply System Water Treatment Plant ("WWSS WTP")** means the Water Treatment Plant to be located in Washington County outside of Wilsonville to be designed, constructed, and serve potable water to TVWD,

Hillsboro, and other potential Parties.

3. Commission

There is hereby created, pursuant to ORS 190, the Willamette Intake Facilities Commission (“Commission”) governed by the Board of Commissioners according to this Agreement and the laws of Oregon. The Commission is created under this Agreement to own and manage the Intake Facilities in order to enable the Parties to this Agreement to draw water through the Intake Facilities to the System Separation Point and convey water to each Water Treatment Plant. The Board is served by appointed Management and Operations Committees and the affairs of the Board are administered by an appointed Managing Agency with an organization structure illustrated in **Exhibit 6**.

4. Board of Commissioners

4.1. Appointment

The Commission shall be governed by a six-Member Board consisting of one person and one alternate person appointed by each Party pursuant to the laws and regulations of the Party’s governing body. A Member serves at the pleasure of the Member’s governing body. The name of the Board is the Willamette Intake Facilities Board (“Board”).

4.2. General Powers and Duties

The Board shall manage the business and affairs of the Commission for the mutual benefit of all of the Parties. The Board shall adopt such bylaws, rules, regulations and policies as it deems necessary in furtherance of the purposes of this Agreement. Subject to the approval of expenditures by the Parties, as set forth in Section 7, the Board shall have the power to hire employees as it deems necessary and to contract for the purchase of property and services. The Board shall perform such further duties as may be required by this Agreement and shall have all powers necessary and incidental to the execution of its specific duties. Except for the provision of

liability of debt obligations as provided for under ORS 190.080, the Board may perform its activities in any manner permitted under ORS 190.030 to 190.150.

4.3. **Duration**

Subject to the dissolution provisions in Section 26, this Agreement is perpetual.

4.4. **Meetings; Manner of Acting**

Board meetings shall be conducted in accordance with the provisions of the Oregon Public Meeting Law, ORS 192.610 to 192.710. The Board shall hold meetings as needed, generally on a quarterly basis, but in no event less than twice a year. Special meetings may be called by the Chair or by any two Members. The Board shall adopt rules governing the conduct of its proceedings.

4.5. **Quorum and Voting**

4.5.1. If a unanimous vote of all Members is required, then all Members must be present to constitute a quorum. In all other cases, five of six Members of the Board shall constitute a quorum for the conduct of business.

4.5.2. Except where a unanimous or Supermajority vote is required, an affirmative vote of five Members is required to decide any issue before the Board.

4.5.3. If the Member and the alternate attend the same meeting, the Member shall be the voting representative for the Party. The Member shall inform the Chair in advance of any meeting if he or she cannot attend and whether the alternate member will attend and will be authorized to vote.

4.6. **Officers**

The Board shall annually elect from its Members a chair and a vice chair, who shall be officers of the Board. The elections shall occur at the first meeting of the Board in each calendar year, unless otherwise agreed. The chair shall serve as the presiding officer. In the absence of the chair, the vice chair shall serve as presiding officer. Officers shall serve at the pleasure of the Board or until a successor is

appointed.

4.7. **Powers and Duties**

The Board shall, among other things:

- 4.7.1. Appoint a Managing Agency, as provided in Section 5, including approval and entry into any agreement(s) with the Managing Agency as described in Section 5.2.
- 4.7.2. Approve an operations and management contract(s) as needed.
- 4.7.3. Annually adopt a budget, as described in Section 7.4.
- 4.7.4. Annually adopt a work plan in association with the budget.
- 4.7.5. Annually approve a five year capital improvement plan that includes the current fiscal year.
- 4.7.6. Adopt contracting rules and serve as the local contract review board under ORS 279A.
- 4.7.7. Approve and periodically update a Master Plan and Operations Plan for the Intake Facilities.
- 4.7.8. Approve the addition of a new Party, as provided in Section 20, subject to unanimous approval of the Board.
- 4.7.9. Approve modifications or amendments to the Exhibits to this Agreement.
- 4.7.10. Approve and periodically update an emergency response and management plan, and related policies and practices, to govern the operation of the Assets in an emergency.
- 4.7.11. Approve and periodically update a Curtailment Plan based on a recommendation from the Management Committee.
- 4.7.12. Consider for approval any Lease that has a term less than one year or longer than five years, as provided in Section 14.
- 4.7.13. Approve and periodically update overuse plans developed under Section 15.

- 4.7.14. Cause an annual audit to be conducted.
- 4.7.15. Obtain appropriate insurance and fidelity coverages.
- 4.7.16. Oversee the management and operation of the Managing Agency.
- 4.7.17. Approve contracts; acquire real property by negotiation, sale or condemnation; and dispose of surplus personal property.
- 4.7.18. Take other actions necessary and proper to manage, operate and maintain the Intake Facilities.

5. Managing Agency

5.1. Initial Appointment of Managing Agency

TVWD is appointed the Managing Agency for an initial term beginning on the Effective Date through June 30, 2032 (“Initial Term”) with formal performance review in 2029 by the Board.

5.2. Subsequent Terms

Once the Initial Term expires or is terminated, the Board may continue with the initial Managing Agency or appoint a successor Managing Agency to manage the business affairs of the Commission. The Board may elect to enter into a written Managing Agency agreement between the designated Managing Agency and the Board. The designated Managing Agency’s subsequent term will be a six year term, effective on July 1, 2032, or other date as agreed to by the Parties. At the end of the fourth year of the term, the full Board shall either re-appoint the Managing Agency for an additional six year term to commence at the end of the current term or direct the Management Committee to obtain proposals for the selection of a Managing Agency. If the Board elects to obtain proposals rather than reappoint the Managing Agency, the Managing Agency may submit a proposal to continue on as Managing Agency. A proposal process will be required for selection of a Managing Agency at a minimum every twelve years. If the Board initiates a proposal process

for the selection of the Managing Agency, at the end of the fifth year of the term, the Management Committee shall submit to the Board a recommendation for a Managing Agency. A Party who submits a proposal to be Managing Agency cannot participate in the selection process. Upon designation of a new Managing Agency, the current and new Managing Agency will be required to create a one year transition plan unless a different period is approved by the Board. The components of the transition plan shall be reviewed and approved by the Management Committee prior to implementation.

5.3. **Contracted Services**

The Board may elect to contract the management of the business affairs of the Commission to a non-Party. In such case, the Board will direct the Management Committee to obtain proposals and provide a recommendation for the award of a contract by the Board. The Board will designate a Party to manage the contract and will adopt an annual work plan. Upon Board approval of the contract, the current Managing Agency will be required to create a one year transition plan unless a different period is approved by the Board. The components of the transition plan shall be reviewed and approved by the Management Committee prior to implementation. The Board may terminate the contract at its sole discretion and appoint a new Managing Agency.

5.4. **Annual Review**

The Management Committee will conduct an annual performance review of the Managing Agency and submit a report to the Board.

5.5. **Termination or Resignation**

The Managing Agency may be terminated at any time at the Board's discretion, or may withdraw at its own discretion. The Board will provide a reasonable notice to

the Managing Agency and Parties if the termination is for convenience and not due to a default. The Managing Agency will provide a notice to the Board if withdrawal is desired. A notice to terminate may specify an effective date for termination or withdrawal. A transition plan with a reasonable period for transfer of duties to the new Managing Agency will be developed by the Board. Termination related to default is covered in Section 24.

5.6. **Powers and Duties of Managing Agency**

TVWD's initial management of the Intake Facilities and Capacity Expansion projects are described in **Exhibit 7** and those terms are only applicable during TVWD's Initial Term. With respect to all other roles and responsibilities of the Managing Agency, the Board may delegate powers to the Managing Agency to provide the management functions required to administer the Commission. The Managing Agency is responsible for administering the business affairs of the Commission. This Section does not prevent the Board, upon a finding that it is in the best interest of the Commission, from modifying the duties of the Managing Agency. The Managing Agency shall act for the mutual benefit of all Parties at all times in the performance of all Managing Agency duties. The Managing Agency duties shall include but are not necessarily limited to the following:

- 5.6.1. Prepare an annual work plan in conjunction with the annual budget.
- 5.6.2. Perform such duties as established in an annual work plan and any other duties as directed by the Board.
- 5.6.3. Provide administration of the Board meetings and required public meeting notices and duties.

- 5.6.4. Maintain records consistent with public records laws.
- 5.6.5. Provide administration of the infrastructure operations and maintenance of the Intake Facilities and associated contract approvals.
- 5.6.6. Perform financial planning and management including payment of invoices, accounting, reporting, and budgeting in accordance with Oregon law.
- 5.6.7. Develop and coordinate capital improvements plans, including the timing of any improvements or expansions as relate to the Intake Facilities. Each Party will participate in planning projects, such as a Master Plan or facilities plan, and will provide good-faith estimates for future Demand.
- 5.6.8. Provide capital project management, unless otherwise directed by the Board.
- 5.6.9. Provide administration and staffing for the Board and committees such as the Management Committee, Operations Committee, and Finance Committee.
- 5.6.10. Prepare an Operations Plan in coordination with the Parties. The Operations Plan must be approved by the Operations Committee prior to submitting it to the Board for adoption.
- 5.6.11. Coordinate with WRWTP and WWSS to support and facilitate the orderly and effective operations, maintenance and construction activities of the Intake Facilities, WRWTP and WWSS.
- 5.6.12. Take prompt action, as necessary, in response to a Curtailment Plan or an Emergency Response Plan and report to the Parties and the Board as soon as reasonably possible. In the case of an emergency, an after-action report

including the nature of the emergency, the effect(s) on the Intake Facilities, and the steps taken by the Managing Agency in response will be provided to the Board.

5.6.13. Procure and manage appropriate insurance coverages and fidelity coverages, in accordance with the insurance requirements set forth in Section 27.3, or as the Board may otherwise direct.

5.6.14. Approve and execute contracts, subject to the contracting rules and direction of the Board.

5.6.15. Other duties as may be assigned by the Board.

6. Management, Operations, Finance, and Other Committees

6.1. Management Committee

Each Party shall appoint its Chief Executive Officer, City Manager, or its designee to serve on the Management Committee. The Managing Agency shall meet with the Management Committee to receive recommendations on policies, planning, operations, capital projects, contract awards, etc., to be forwarded to the Board. The Management Committee members will also serve as the liaison to each of their respective governing bodies and shall be charged with authority to act on behalf of the Party's governing body, except as otherwise provided herein.

6.2. Operations Committee

Each Party shall appoint one person technically knowledgeable in water system operations or engineering to the Operations Committee. A Party may allow other attendees, but in no event will a Party have more than one vote in making a recommendation to the Management Committee. The Managing Agency will advise and consult with the Operations Committee on matters including but not

limited to Intake Facilities operations, capital improvements and planning, and contract management. The Operations Committee shall, as required by this Agreement or requested by the Management Committee, report on or provide recommendations to the Management Committee on any such matter.

6.3. **Finance Committee**

Each Party shall appoint one person, knowledgeable in municipal finance laws and practices, to the Finance Committee. A Party may allow other attendees, but in no event will a Party have more than one vote in making a recommendation to the Management Committee. The Finance Committee shall provide recommendations to the Management Committee on the proposed annual budget, capital improvement plan including resource availability and timing, and other financial policies. The Finance Committee will also provide comment and recommendations on the financial procedures to be developed and implemented by the Managing Agency.

6.4. **Other Committees**

Other Committees may be formed as needed to support and provide guidance to the Commission.

7. Financial Management

7.1. **Budget Process and Calendar**

The Board shall adopt a budget for its operations and capital improvements for each Fiscal Year. The Managing Agency shall annually prepare a budget for administration, operations, and capital improvements in coordination with the appropriate committees representing the Parties as described in this Section. The budget review process shall follow the schedule described in **Exhibit 8** unless a

modified schedule is approved by the Board.

7.2. **Operations and Finance Committees Budget Review**

An initial draft budget shall be prepared and distributed by the Managing Agency to the Operations and Finance Committees. The initial draft budget shall include estimates for full-time equivalents, associated benefits, materials and services, a listing of contracts in effect and contemplated for future periods, capital outlay, and any other necessary expenditures. The initial draft budget shall also include supporting detail and assumptions for the Committee's consideration. Joint meeting(s) of the Operations and Finance Committees will be held as needed to refine the initial draft budget. The Operations and Finance Committees will review the initial draft budget, and will provide its recommendation, after any requested revisions are incorporated by the Managing Agency, to the Management Committee. The Managing Agency will incorporate such revisions and prepare a revised draft budget for consideration by the Management Committee.

7.3. **Management Committee Budget Review**

The revised draft budget shall be distributed to the Management Committee as described in **Exhibit 8**, but not later than March 15th of each year. The Management Committee will review the revised draft budget, and will either provide a recommendation to the Board for adoption or provide requested revision(s) to the Managing Agency. Following Management Committee review and revisions, the Managing Agency shall prepare a proposed budget and distribute it to the Board.

7.4. **Budget Adoption**

The Board will consider the proposed budget consistent with the schedule presented in **Exhibit 8**. Furthermore, the Board will strive to adopt the budget by resolution in April of each year to enable the Parties to adequately reflect necessary commitments in their own respective budgets, but in no case will the Board adopt

the annual budget later than June 1st of each year. The adopted budget shall include estimated subtotals for the categories of personnel services, materials and services, capital outlay, and all other appropriation categories used in the adopted budget. The adopted budget shall also include a narrative describing the supporting detail and assumptions summarized for the Board's consideration, including personnel counts stated as full-time equivalents. Each Party's proportionate share of expenses of operations and maintenance of the Intake Facilities, including reserves and replacements, debt services, payments to the Managing Agency, and all other expenses as may be incurred by the Commission, shall be estimated by the Managing Agency and set forth in the Commission's adopted budget.

7.5. **Capital Improvement Plan Budget**

The Managing Agency shall maintain capital improvement plan budget projections for at least the subsequent four Fiscal Years following the fiscal year budgeted, which shall be updated annually and submitted with the initial draft budget and the proposed budget. The Operations and Finance Committees will review the proposed capital improvement plan, and will provide a recommendation to the Management Committee for review or provide requested revision(s) to the Managing Agency for incorporation. The Management Committee will review the proposed capital improvement plan, as may have been revised by the two committees, and will provide a recommendation to the Board for adoption or provide requested revision(s) to the Managing Agency for incorporation. The Managing Agency will include the capital improvement plan budget, as reviewed and revised by the Management Committee, in the proposed budget and submit it to the Board. The Board will consider the capital improvement plan for adoption on an annual basis on the same timeline as the annual budget. The capital outlay category includes routine purchases as well as major improvements or expansions

as may be outlined under the provisions of Section 17.

7.6. **Accounting**

The Managing Agency shall comply with government accounting standards, maintain independent budget and accounting control procedures, and provide budget financial status reports at least quarterly to the Board and to each of the Parties not later than 30 days after the end of each quarter. The report shall show expenditures and receipts consistent with the requirements of the financial procedures described in Section 7.9. The Managing Agency shall maintain all fiscal records relating to the Intake Facilities and associated capital improvement projects in accordance with generally accepted accounting principles. In addition, the Managing Agency shall maintain any other records pertinent to the Intake Facilities and associated capital improvement projects in such a manner as to clearly document the Managing Agency's performance hereunder. All such fiscal records, books, documents, papers, plans, and writings shall be retained by the Managing Agency and kept accessible as required by law. The Managing Agency agrees that the other Parties and their authorized representatives shall have access to all books, documents, papers and records of the Managing Agency which are directly related to the Intake Facilities and associated capital improvement projects for the purpose of making any audit, examination, copies, excerpts and transcripts.

7.7. **Audit**

The Board shall cause an independent audit of the financial affairs of the Commission to be performed by a certified public accountant licensed and certified to do municipal auditing in the State of Oregon. The audit shall be performed in accordance with the provisions of the Oregon Municipal Audit Law, ORS Section 297.405 – 297.555. The audit shall be completed annually within six months following the end of each Fiscal Year. The Board shall review, accept the annual

audit, and direct the Managing Agency to complete correction actions as needed. A copy of the annual audit shall be provided to each Party upon acceptance by the Board.

7.8. **Issuance of Debt**

When authorized by a unanimous vote of the Board and an affirmative vote by the governing body of each Party, the Board may issue debt under ORS 287A, as allowed under ORS 190.080, as the Board deems necessary to finance capital improvements. Upon receipt of an affirmative vote of each of the governing bodies, the Board shall approve the order or resolution authorizing the issuance of debt, which shall specify the joint and severable liabilities and obligations of the Parties as set forth in ORS 190.080 (3).

7.9. **Financial Procedures**

Interim financial procedures are included as **Exhibit 9**, and will be used until the long-term financial procedures are developed and approved by the Board. The Managing Agency shall propose financial procedures consistent with the requirements of this Section. The Finance Committee will review the proposed financial procedures, and will provide a recommendation to the Management Committee for review or provide requested revision(s) to the Managing Agency to incorporate and forward to the Management Committee. The Management Committee will review the proposed financial procedures, and will provide a recommendation to the Board for adoption or provide requested revision(s) to the Managing Agency to incorporate and forward to the Board. The Board will consider the recommended financial procedures for adoption or send back to the Management Committee for modification. The financial procedures will be reviewed and updated on at least a ten-year basis or as requested by the Finance Committee, Managing Agency, or the Board. The Board approved long-term

financial procedures will be included as an amended **Exhibit 9** to this Agreement subsequent to the effective date of this Agreement.

8. Intake Facilities Ownership and Easement

8.1. Capacity Ownership

The Parties each own various shares of Capacity in the Intake Facilities. The ownership of each Party is a percentage share of the Intake Facilities that is equal to the Party's Capacity in MGD compared to the total Capacity of the Intake Facilities. The Parties' respective shares of the anticipated design Capacity of the Intake Facilities are set forth in **Exhibit 3**. Upon completion of construction, the Board shall determine ownership of Capacity based on actual Capacity achieved of the Intake Facilities to the System Separation Point. If the actual Capacity achieved is more or less than the design Capacity anticipated in **Exhibit 3**, the **Exhibit** will be revised to reflect the ownership based on the actual Capacity achieved. The Capacity shares shall be proportionately increased or reduced. If the actual Capacity achieved is less than the design Capacity anticipated, in no event will the Capacities of TVWD, Wilsonville and Sherwood be less than 56.5 MGD, 20 MGD and 5 MGD, respectively.

8.2. Easement

The Intake Facilities have been granted an Easement described in **Exhibit 1** and are located on the Real Property described in **Exhibit 4**.

9. Water Rights

9.1. Existing Water Rights

A Party shall continue to hold its Water Rights in its individual name, except that TVWD, Sherwood, Tigard and Tualatin jointly hold their Water Right through the WRWC. **Exhibit 5** identifies the Water Rights held by each Party and the WRWC for use at the Intake Facilities Point of Diversion and as described in this Section.

9.2. **Restriction on Use**

If surface water withdrawal rights are partially or fully restricted and unavailable, then each Party will be subjected to the restrictions and conditions applicable to its own Water Rights. The available Water Rights will be used for the benefit of the Party(ies) that own(s) the Water Rights. To the extent that the non-restricted or partially restricted Water Rights are greater than that required by the Party owning the Water Rights, then the unused portion of the Water Rights may be leased to the other Parties, as set forth in the leasing provisions. In times of emergency or curtailment, the Board may allow Parties to use the Water Rights of other Parties without a leasing requirement, subject to the agreement of those Parties. Those Water Rights held jointly through WRWC shall be allocated for use by the WRWC Parties as described in the WRWC agreement.

9.3. **Supplemental Water Rights**

A Party or the Commission may obtain additional Water Rights from the Oregon Water Resources Department or a federal agency that initiates a municipal contracting program in the United States Army Corps of Engineers storage facilities in the Willamette Basin (“Willamette Basin Project”) as the Demand and need is identified. The Board will establish Capacity ownerships of any jointly held Water Right by the Commission at the time of application. **Exhibit 5** identifies the Water Rights authorized for use at the Intake Facilities Point of Diversion held by individual Parties and those jointly held by the WRWC or by the Commission. **Exhibit 5** will be updated by the Board as additional Water Right transactions occur.

9.4. **Obligations of Each Party**

Each Party is responsible for obtaining its own Water Rights with a point of diversion at the Intake Facilities sufficient to meet its Capacity.

9.5. **Perfection and Certification**

A Party's certification or perfection of its individual Water Right through the Intake Facilities cannot exceed the Party's owned Intake Facilities Capacity unless the Board approves otherwise and such approval is not to the detriment to the other Parties' Water Rights.

10. Use of the Intake Facilities by the Parties

Each Party shall use the Intake Facilities in a manner consistent with prudent water utility operating practices and in a manner that minimizes the impact of use on the other Parties. The Managing Agency shall manage the Intake Facilities for the mutual benefit of all Parties. Each Party shall obtain sufficient Capacity in the Intake Facilities to serve the Demand imposed on the Intake Facilities by the Party.

11. Operations Plan

Prior to the date the Willamette Water Supply System commences delivery of potable water to its respective Users, an Operations Plan shall be developed by the Operations Committee with support from the Managing Agency, and submitted to the Management Committee. The Management Committee will review the proposed Operations Plan, will work with the Managing Agency on modifications, and will provide a recommendation to the Board for adoption or will send back to the Operations Committee for modification. The Operations Plan for the Intake Facilities will include, but is not limited to, agreed protocols and a methodology to provide for the equitable, effective and efficient operation of the Intake Facilities in accordance with generally accepted utility practices regarding the operation, management, capital improvements, and expansion of all aspects of the Intake Facilities. The Operations Plan will provide that the Parties will use best efforts and good faith in the operation of the Intake Facilities for the mutual benefit of all Parties. The Operations Plan will be updated as needed. The agency responsible for operating the Intake Facilities shall follow the Board-

adopted Operations Plan.

12. Curtailment Plan and Emergency Response and Management Plan

12.1. Curtailment Plan

The Board shall adopt a Curtailment Plan that establishes policies and procedures for when and how reductions in Demand shall be made. The Managing Agency shall develop a proposed Curtailment Plan for review by the Operations Committee. The Operations Committee will review the proposed Curtailment Plan, and will provide any requested revision(s) to the Managing Agency before presentation to the Management Committee. The Management Committee will review the proposed Curtailment Plan, and will either provide a recommendation to the Board for adoption or will send back to the Operations Committee for further review and modification. The Management Committee will provide a recommendation to the Board for its consideration and adoption. When reductions in Demand become necessary, the reduction shall be in accordance with the Curtailment Plan. Any Curtailment Plan must treat all Parties fairly and equitably.

12.2. Emergency Response Plan

The Managing Agency shall prepare an Emergency Response Plan to be reviewed by the Operations Committee and the Management Committee. Procedures and protocols will be included in the proposed Emergency Response Plan. The Operations Committee and Management Committee will review the proposed Emergency Response Plan, and will either provide a recommendation to the Board for adoption or will provide requested revision(s) to the Managing Agency.

13. Right of First Offer

Wilsonville and TVWD entered into the 2000 Master Agreement, Accord, First Amendment and the Willamette Intake Facilities Agreement regarding the construction, joint ownership, and continuing operations of the WRWTP, which all remain and will remain in full force and

effect, except as otherwise amended, in writing, by TVWD and Wilsonville. The Accord Agreement, dated June 19, 2001, expressly provides a Right of First Offer be made between Wilsonville and TVWD with respect to any sale, transfer, exchange, grant of option to purchase, lease, or other disposal of their respective interests in the Property, or any part of, or interest in, or ownership interest in the Supply Facilities (which include the Intake Facilities). Wilsonville has been offered and declined the first right to purchase the Intake Facility capacity held by TVWD and consented to sale, purchase and transfer of 62.3 MGD of existing and expanded capacity between TVWD and the other Parties to this Agreement and waived further application of the Accord Agreement thereto. In accordance with the Accord Agreement, the reciprocal Right of First Offer with respect to Intake Facilities remains in full force and effect with respect to 56.5 MGD of TVWD's retained interest in the Intake Facilities and Wilsonville's 25.0 MGD retained interest in the Intake Facilities, notwithstanding anything to be construed to the contrary in this Agreement. Additional terms with respect to the Right of First Offer continue to apply and are detailed in the Accord Agreement. If TVWD or Wilsonville declines to lease or purchase all or a portion of the amount offered, then the declined amount may be offered to the Parties for lease or for purchase, as provided in Sections 14 and 19. Notwithstanding the terms of the Right of First Offer, Wilsonville and TVWD do hereby agree to waive their Right of First Offer for leases of five years or shorter duration offered by Wilsonville or TVWD to the other Parties ("Short Term Waiver"). A lease to which this Short Term Waiver applies may be renewed for one additional term and the Short Term Waiver is applicable for that one time renewal.

14. Leasing

14.1. Leasing

The Parties recognize that options for leasing Capacity in the Intake Facilities or Water Rights are important to maintain the cost effective and efficient use of the Intake Facilities and associated infrastructure. Only Parties to this Agreement are

eligible to engage in leasing. Leasing options will include firm, interruptible, and surplus water pool. A Party will not be forced to lease its Capacity in the Intake Facilities or Water Rights to other Parties. Each Party retains sole discretion as to how much, if any, Capacity of the Intake Facilities or Water Rights to make available for leasing. Prior to expanding or adding new infrastructure to the Intake Facilities above 150 MGD, the Parties will determine if leasing options are a reasonable approach as a method to defer capital expansion. The following provisions regarding Leasing are subject to the Right of First Offer, including the Short Term Waiver between TVWD and Wilsonville, as set forth in Section 13.

14.2. **Leasing Procedures**

The Managing Agency will coordinate and manage the annual leasing process, including associated agreements and approval requirements, on a schedule that accommodates the Commission and the Parties' budget processes. The Managing Agency will request available Capacity or Water Rights for leasing options from all Parties who are interested in leasing on an annual Fiscal Year basis prior to the Peak Season. Each interested Party will estimate the amount of Capacity, duration, and type of Lease (interruptible or firm) or Water Rights it wishes to make available to lease to, or the amount of Capacity, duration, and type of Lease (interruptible or firm) it seeks to lease from, the other Parties. The Managing Agency will develop forms and protocols for managing the leasing process including the leasing requests and annual surplus Capacity designated by each Party. A rate methodology for each of the leasing options will be developed by the Managing Agency, reviewed and recommended by the Management Committee and the Finance Committee, and adopted by the Board. A sample Lease form and methodology are attached in **Exhibit 10**, which may be modified and/or updated by the Board. In those years when Water Rights are limited and if requested by the Parties, the Board may adopt

an equitable methodology for leasing of the Water Rights.

14.3. **Firm and Interruptible Lease Terms**

The length of time for firm and interruptible leases will be a minimum of one year and a maximum of five years, unless otherwise approved by the Board and subject to the Right of First Offer provisions. The Capacity acquired from a firm Lease will be considered transferred Capacity from the lessor to the lessee for the quantity and the duration of the Lease agreement for use and overuse purposes. The Capacity acquired from an interruptible Lease will be considered the lessee's Capacity for use and overuse purposes until the lessor calls back the Capacity from the lessee pursuant to the terms of the Lease. The Managing Agency will develop recommended protocols and the terms to be approved by the Board for firm and interruptible Leases, the latter of which will include the terms under which a lessor may call back the "interruptible" leased Capacity, such as when curtailment or loss of Capacity occurs.

14.4. **Surplus Capacity Pool Terms**

When excess Capacity is made available for leasing that is not dedicated to a firm or interruptible Lease, that excess Capacity shall be included in the Surplus Capacity Pool to be made available for a period not to exceed one year from the date of placement in the Surplus for lease for less than one year by the Parties in coordination with the Managing Agency. The premium short term lease rate is included in **Exhibit 10**, and may be amended by the Board. The Managing Agency will develop for approval by the Board the terms, costs, and protocols for the management and use of the Surplus Capacity Pool, taking into account the best interests of the Parties while maintaining the integrity of the system.

14.5. **Lease Approval**

A Lease that is within the terms of this Section will be reviewed and approved by

the Management Committee and administered by the Managing Agency. Status reports regarding the Lease agreements will be provided to the Board by the Managing Agency. A Lease that is not consistent with the terms of this Section must be approved by the Board.

14.6. Lease Distribution and Payments

Lease requests and associated Lease revenues will be divided among the lessors based on the percent of Capacity or Water Rights leased, if more than one lessor and one lessee are involved unless otherwise approved by the Board. A Lease approved between two Parties may provide for payment made directly from the lessee to the lessor. When Lease requests exceed the amount of Capacity or Water Rights made available, available Lease Capacity or Water Rights will be divided amongst the lessees based on the percent of Capacity or Water Rights requested unless otherwise approved by the Board.

15. Overuse

15.1. Notification

A Party will manage its Demand on the Intake Facilities within the Party's respective ownership and Capacity share of the Intake Facilities as may be augmented by firm, interruptible or surplus Capacity pool Lease sources. Overuse terms are included in the Agreement in order to discourage use that may result in adverse impacts to the operational integrity of the Intake Facilities and to promote prudent planning of needed expansions. The Managing Agency shall notify a Party when the Party's instantaneous Demand has exceeded its Capacity ownership as augmented by any leased Capacity, including any short term lease from the Surplus Capacity Pool of the Intake Facilities. A Party should notify the Managing Agency if the Party exceeds or anticipates exceeding its Capacity share as augmented by any leased Capacity and short term lease from the Surplus Capacity

Pool. A Party will be required to take appropriate corrective action to decrease the Party's Demand on the Intake Facilities to be within its Capacity ownership as augmented by any leased Capacity and the surplus Capacity pool. A Party shall be deemed to have overused the Intake Facilities if the Party's Demand on the Intake Facilities exceeds the Party's Capacity as described in Sections 8 and 10. Overuse is subject to remedies described in Section 16.

15.2. Overuse Terms

If a Party has been notified by the Managing Agency that their instantaneous Demand on the Intake Facilities has exceeded their ownership Capacity as augmented by any leased Capacity and the surplus Capacity pool, and corrective action was not taken to decrease the Demand within their ownership Capacity as augmented by any leased Capacity and the surplus Capacity pool, then the following Overuse Terms shall apply. A Party shall be deemed to have overused the Intake Facilities if the Party's Demand on the Intake Facilities exceeds the Party's Capacity as augmented by any leased Capacity and the surplus Capacity pool by 5% continuously over a 12 hour period for: i) three consecutive days in two consecutive years or ii) three consecutive days in any three years out of a five year period. Overuse also includes a Party's use exceeding its Water Right ownership regardless of the extent of overuse during times of regulation or curtailment per Section 12, unless otherwise approved by the Board. If overuse occurs, then the Party shall be subject to the remedies for overuse terms set forth in Section 16.

16. Remedies for Overuse

16.1. Remedies Considered by the Board

To the extent that a Party overuses the Capacity or Water Rights of the Intake Facilities as defined in Section 15 of this Agreement, the Party shall compensate the other Parties as set forth in Section 16.2. When overuse occurs, the Board may

require the Party to lease Capacity or Water Rights in the Intake Facilities, reduce Demand on the Intake Facilities, or purchase Capacity in the Intake Facilities, if made available by another Party such that the overuse will cease to occur. Compensation for overuse is described in Section 16.2. The Party that overused the Intake Facilities shall deliver to the Management Committee and the Board a plan to avoid overuse in the future. The plan must include a proposal for a Lease agreement, a Capacity purchase agreement, and/or other measures to eliminate overuse of the Intake Facilities. Nothing herein shall compel a Party to lease or sell Capacity or Water Rights to an overusing Party. The Board shall approve a plan to eliminate overuse by the Party, and the Managing Agency shall monitor the implementation of the plan and report back to the Board. Penalties for overuse may only be waived by the Board. A request for a waiver may be given to the Managing Agency, along with justification for the waiver, to be presented to the Board.

16.2. Compensation

To the extent that a Party overuses the Capacity or Water Rights of the Intake Facilities as defined in Section 15 of this Agreement, the Party shall compensate the other Parties. Unless modified by the Board, compensation for overuse shall be five times the firm Lease rate for Capacity, which would have been in effect in the last period described above in which the overuse occurred for the entire period of the overuse (i.e. two consecutive or three out of five years). The amount of Capacity overused for the determination of retroactive compensation shall be equal to the difference between the Party's Capacity as augmented by any leased Capacity or surplus Capacity pool and the Demand imposed by the Party during the overuse period. The compensation for overuse shall be distributed to the other Parties by their ownership Capacity percentage.

17. Expansion and Capital Improvements

17.1. **Current Expansion**

As described in the Recitals, the Parties have or will enter into separate agreements to design and construct upgrades for a Capacity Expansion of the Intake Facilities to achieve a design Capacity of 150 MGD. The preliminary concept and layout for the Intake Facilities improvements are shown in **Exhibit 2**. The preliminary cost allocations for the Intake Facilities improvements are described in **Exhibit 11**. The process set forth in Sections 17.2 and 17.3 shall not apply to this current Capacity Expansion.

17.2. **Future Expansion or Improvement**

Capacity Expansion of the Intake Facilities refers to any capital improvement project not part of Section 17.1 that results in increased Intake Facilities Capacity. Capacity Expansion or Facilities Modification of the Intake Facilities, to the extent possible, shall be planned for through a Master Plan to be updated not less than every five years. The Managing Agency will lead and facilitate the development of the Master Plan, which will be reviewed and recommended for adoption by the Operations and Finance Committees to the Board. The Managing Agency will conduct the planning and implementation of the Intake Facilities Capacity Expansion, including provision for minimum operational impacts and cost impacts, to the other Parties using the Intake Facilities. A Party will notify the Managing Agency of any proposed Capacity Expansion outside the planned Capacity Expansions including the proposed Capacity and schedule.

17.3. **Determination of Future Expansion**

The Managing Agency will provide notice to the Parties of any proposed Capacity Expansions to determine participation. Parties shall have 120 days from the date they receive notice, with an option for an additional 60 days if requested, in which to respond to the Managing Agency whether they wish to participate in the

proposed Capacity Expansion and any proposed conditions for participation. Once participation in the proposed Capacity Expansion is fixed and the scope, budget, and schedule are established, then the non-participating Parties shall have no further opportunity to participate unless all participating Parties approve. Participating Parties will include their proportionate share of the estimated costs in their respective annual budgets. In the case of any proposed Capacity Expansion, a Supermajority of the Board must agree to the proposed Capacity Expansion. If the Board agrees to allow the Capacity Expansion, each Party will have the option to participate in the Capacity Expansion. If not all Parties agree to participate in the Capacity Expansion, then only those Parties electing to participate in the Capacity Expansion will be responsible for all costs related to the Capacity Expansion. The Managing Agency will strive to resolve objections to proposed Expansion prior to a final decision being made with respect to the Capacity Expansion.

18. Sale of Water to Non-Party

The Parties agree that sale of water to a non-party shall occur only through the associated Water Treatment Plant agreements. Parties that require Capacity for such sales shall lease Capacity from other Parties to this Agreement pursuant to Section 14 or purchase Capacity from other Parties pursuant to Section 19.

19. Withdrawal and Sale of Interest

19.1. Notification

Subject to the notification requirements of the Right of First Offer described in Section 13, one or more Parties (“Selling Parties”) may sell all or a portion of their ownership Capacity in the Intake Facilities by providing written notice to the Managing Agency and the other Parties. Within 60 days of receipt of the notice, each Party with an interest in acquiring additional Capacity in the Intake Facilities shall respond in writing to the Managing Agency and the Selling Party indicating

whether it wishes to purchase all or a portion of the interest in the Intake Facilities, the offer price, and the proposed terms and conditions of the purchase and sale (“Purchase Nomination”).

19.2. Purchase Nomination Recommendation

The Managing Agency will review each Purchase Nomination and make a preliminary determination as to whether all Parties submitting a Purchase Nomination (“Purchasing Parties”) and Selling Parties can be accommodated in full. If the Managing Agency is a purchaser or seller, then the Management Committee will perform the tasks outlined in this Section. If all Purchasing and Selling Parties can be accommodated in full, the Managing Agency shall notify the Selling Parties and Purchasing Parties of how the reallocation of ownership will be calculated. If all Purchasing and Selling Parties cannot be satisfied in full, then the Managing Agency will confer with the Purchasing and Selling Parties individually or collectively and make a recommendation as to how the total interest designated for sale should be allocated among the Purchasing and Selling Parties. The Managing Agency shall allocate proportionately in order to achieve an equitable and fair solution for the Purchasing and Selling Parties. The Managing Agency will make the recommendation to the Management Committee with respect to the proposed allocation within 30 days after receipt of Purchase Nominations.

19.3. Purchase Negotiations

Within 30 days after the Managing Agency makes the recommendation and provides written notice of the proposed allocation (as approved by the Management Committee), the Managing Agency will convene a meeting of the Selling Party and the Purchasing Party to reach final agreement on the allocation of Capacity, the purchase price to be paid and other terms of sale. The Purchasing Party and Selling Party will each designate a representative for negotiations. As a result of the

negotiations, one price will be set that will apply to all Selling and Purchasing Parties.

19.4. Purchase Term Sheet

All Purchasing Parties and Selling Parties, with the Managing Agency as the facilitator, will have 60 days to negotiate a fair and equitable transaction through a process so that all Purchasing and Selling Parties are privy to all discussions of price and terms resulting in a mutually agreed final reallocation of Intake Facilities ownership and the terms of purchase and sale. The final terms will be reduced to a term sheet for tentative approval by the designated representatives of the Purchasing and Selling Parties. If the Managing Agency is a Purchasing Party or a Selling Party, the Management Committee will assume the facilitator role throughout the purchase and sale process.

19.5. Acceptance or Rejection

Within 45 days of approval of a term sheet, each Purchasing and Selling Party will conduct such internal review as it deems necessary and provide written notice of intent to proceed with or decline the transaction to the other Parties and the Managing Agency. If any Purchasing or Selling Party declines, then the Managing Agency will convene the remaining Purchasing and Selling Parties who will then determine how to reallocate the Capacity and adjust their respective purchase price or terms. If there is excess Capacity available, the Managing Agency may also offer the excess Capacity to those Parties who had earlier declined to be a Purchasing Party. Those declining Parties shall have 15 days from notice by the Managing Agency to accept or decline the term sheet as is and without opportunity to vary its terms unless the Purchasing Party and Selling Party mutually agree.

19.6. Purchase and Sale Agreement

Once the terms of purchase and sale are determined, the Managing Agency shall

notify all Parties of the pending transaction. Purchasing and Selling Parties will prepare the necessary documents for final approval by the governing bodies of the Selling and Purchasing Parties and the transaction will close within 30 days after approval, unless a longer period is agreed to by the Selling and Purchasing Parties. Upon closing of the transaction the Managing Agency will undertake to gather or prepare amended Exhibits and other documents necessary to memorialize the transaction and will enter the revised Capacity allocation and resulting equity interest on the books and records of the Commission. Board approval of the transaction is not required, but the Board will approve the amended Exhibits that reflect the revised Capacity allocations.

19.7. Commission's Purchase Rights

If all or a portion of the offered Capacity remains unsold after the exhaustion of the procedure in Sections 19.1 through 19.6 above, the Board will have the right to consider whether to purchase a Selling Party's interest on terms and conditions agreed upon by the Board and the Selling Party. If so acquired, the Commission will hold the Capacity in trust for the benefit of all of the Parties.

19.8. Sale to Municipal Non-Party

If all or a portion of the offered Capacity remains unsold after the exhaustion of the procedure in Sections 19.1 through 19.7, then the Selling Parties may seek and obtain offer(s) from a non-Party so long as the non-Party is a Municipal Water Provider and becomes a Party to the Commission and this Agreement. Such offers will be reviewed in accordance with Section 20.

19.9. Party Status

If the interests of the Selling Party remain unsold, then the Selling Party will continue as a Party. Upon sale of all ownership interests, the Selling Party will cease

to be a Party.

19.10. **Water Rights**

The process described in this Section does not govern the sale or purchase of Water Rights.

19.11. **Schedule**

Participating Parties in any proposed transaction may adjust the schedule provided in this Section as mutually agreed.

20. Admission of New Municipal Parties

20.1. **Eligibility**

Only a Municipal Water Provider is eligible to apply to become a Party and must make a written request to become a Party (“Applicant”).

20.2. **Applicant Request**

The Applicant’s written request shall state the proposed date of joinder, Demand and Capacity sought to be purchased, identify the quantity and status of Water Rights the Applicant would provide, identify the existing Capacity necessary to serve the Applicant, identify any improvement(s) that would need to be built or expanded to accommodate the Applicant, and other supply sources available to Applicant.

20.3. **Consideration by Managing Agency and Board**

The Applicant shall deliver its request to the Managing Agency who shall then distribute it to the Board and the Management Committee. Each Party’s representative of the Management Committee will be responsible for presenting the application to their respective governing bodies for a recommendation to approve or deny. Once the Management Committee reports back the results from each of the Party’s respective governing bodies, at the next regularly scheduled Board

meeting, the Board will consider the request. A decision to consider an application for admission will require a unanimous affirmative vote of the Board. If the Board determines that the application will not be considered, the Managing Agency will inform the Applicant the request is denied and the matter will be deemed concluded.

20.4. **Provision of Additional Information**

If the Board unanimously votes to consider the admission, the Board, through the Managing Agency, shall request that Applicant provide all information as the Board deems necessary, in its sole discretion, to adequately consider the matter. This may include a request for oral presentation by Applicant's staff and/or elected officials.

20.5. **Term Sheet**

Based on the information submitted, the Board shall determine if there is unanimous interest to continue to consider the request. If so, then the Managing Agency shall deliver a term sheet to the Applicant defining the terms and conditions for joinder, including but not limited to the date of joinder, the method of payment for existing Capacity and Applicant's obligations for construction of new Intake Facilities or expansion of existing Intake Facilities.

20.6. **Applicant Review of Term Sheet and Negotiation**

The Applicant shall have 30 days from the receipt of the term sheet to accept or decline the term sheet, or propose modified terms. If the term sheet is acceptable to the Applicant and the Board, or if the Applicant and the Board negotiate and reach agreement within 30 days on the proposed modified terms, the Managing Agency shall cause a joinder agreement to be prepared for approval by the Applicant and the Board. If declined, the matter will be deemed terminated without any further action.

20.7. **Sale or Transfer to Applicant**

In accordance with Section 19, if an existing Party wishes to sell or transfer Capacity ownership to an Applicant, the Party seeking to sell shall give notice to the Managing Agency as provided in Section 19, Sale of Interest. The Party shall also include a written statement of its intent to sell. Thereafter, the evaluation of the Applicant and terms and conditions of joinder shall follow the process of Applicant request under this Section concurrent with the Sale of Interest provisions of Section 19 for the Selling Party and remaining Parties.

21. Indemnity

21.1. Indemnification of Board, Officers and Employees

Except as may otherwise be provided by contractual agreement between the Commission or Board and any agent of the Commission, including but not limited to the Managing Agency, the Commission shall defend and indemnify any Board member, officer, committee member, employee or agent of the Commission who was or is a party, or is threatened to be a party, to any threatened or actual action, suit or proceeding, whether civil, criminal, administrative or investigative (other than an action by the collective Parties under this Agreement), by reason of the fact that such person is or was a Board member, officer, committee member, employee, or agent of the Commission, against all reasonable expenses, attorney fees, judgments, fines and amounts paid in settlement actually and reasonably incurred by said person in connection with such suit, action or proceeding if such person acted in good faith and such person reasonably believed his or her conduct to be lawful. The termination of any action, suit, or proceeding by judgment, order, settlement, or conviction, or with a plea of nolo contendere or its equivalent shall not in and of itself create a presumption that the person did not act in good faith or did not reasonably believe his or her conduct to be lawful. Payment under this clause may be made during the pendency of such claim, action suit or proceeding

as and when incurred, subject to the right of the Commission to recover such payment from such person, should it be proven at a later time that such person had no right to such payments. Any person who is ultimately held liable for his/her good faith and reasonably believed to be lawful actions on behalf of the Commission as a Board Member, officer, committee member, employee, or agent of the Commission shall be fully covered by this indemnity. Any person who is ultimately held liable but is determined by the Board to have acted in bad faith or without reasonably believing his or her conduct to be lawful shall not be indemnified by the Commission but may have a right of contribution over and against any other Board Members, officers, committee member, employees, agent of the Commission, or Parties who, in bad faith or without reasonably believing his or her conduct to be lawful, participated in the action that created said liability. As used herein, “person” refers to an individual or an entity.

22. Default

22.1. Generally

A Party is deemed in Default of this Agreement if the Party violates any provision of this Agreement or fails to perform an obligation required to be performed or otherwise breaches this Agreement. An Event of Default shall be deemed to have occurred if the Defaulting Party fails to cure the Default within the cure period designated in this Section.

22.2. Notice of Default and Cure

A written notice of Default (“Notice of Default”) shall be delivered to the Party in Default (“Defaulting Party”) by the Managing Agency, acting at the direction of the Board. The Notice must specify the nature of the Default and provide a specified period to cure the Default or otherwise reasonably commence to cure the Default in a diligent manner. A reasonable cure period (“Cure Period”) shall be

deemed to be 30 days unless another time for cure is set by the Board and contained in the Notice of Default. The Notice of Default may also include a requirement to engage in the Dispute Resolution process. A copy of the Notice of Default shall be delivered to all other Parties. Specific provisions relating to Default by the Managing Agency are found in Section 24.

22.3. Response by Defaulting Party

22.3.1. Nonpayment Default

The alleged Defaulting Party shall either: (1) make payment in full by the date set in the Default notice; (2) submit a plan for repayment that the Board must approve; or (3) request Dispute Resolution. The Cure Period for non-payment is a 30 day period, but the Board may, in its sole discretion, approve a payment plan in extraordinary circumstances.

22.3.2. Other Defaults

The Defaulting Party must: (1) cure the Default by the Cure Period set forth in the Notice of Default; (2) state why the Default cannot be cured within the Cure Period, what efforts the Defaulting Party has made to Cure the Default and provide a reasonable plan to cure the Default; or (3) request Dispute Resolution. The Board must approve the plan for cure and if not approved, an Event of Default will be declared. If Dispute Resolution is requested by the Defaulting Party of the Board, then that process will be followed.

22.3.3. Failure to Cure

Failure to cure the Default within the allowed Cure Period will result in the Declaration of an Event of Default, and a Final Notice to Cure will be delivered to the Defaulting Party by the Managing Agency. The Final Notice to Cure will contain one final allowed Cure Period. Failure to cure

the Event of Default within Final Notice of Default Cure Period will result in a Declaration of Default and the Remedies for Default will apply.

23. Remedies

23.1. Determination of Remedy

Upon Declaration of an Event of Default, the Board will determine an appropriate remedy. The Defaulting Party will not have voting privileges regarding the appropriate remedy and a Supermajority vote of the remaining Board Members shall be required to determine the remedy. The imposition and scope of remedies by the Board is subject to Dispute Resolution. In making a determination of remedy for the Default, the remaining Board Members shall consider:

23.1.1. The nature of and severity of the Event of Default and resulting impact on the other Parties;

23.1.2. Whether the factors leading to the Event of Default were beyond the reasonable control of the Defaulting Party;

23.1.3. The Defaulting Party's history of performance and satisfaction of obligations and duties under this Agreement;

23.1.4. The Defaulting Party's responsiveness and cooperation to cure the Event of Default, including consideration of how proactive the Defaulting Party was in revealing the Default.

23.1.5. Other factors that the Board deems relevant.

23.2. Potential Remedies for Consideration by the Board

The Board may consider all remedies available at law, or in equity, for breach of this Agreement as provided in this Section and Section 24. The purpose of the remedy is to make all non-Defaulting Parties whole and to bring the Defaulting

Party into compliance, if possible. The remedies, until the Event of Default is cured, may include, but not be limited to, the following:

23.2.1. Loss of Voting Privileges

The loss of voting privileges such that a Supermajority of the remaining Members of the Board may conduct business without the Defaulting Party until the Defaulting Party fully cures the Event of Default.

23.2.2. Money Damages

The Board may recover money damages for additional costs of service, costs of capital and other actual costs incurred by the other Parties resulting from the Default, plus interest at the statutory judgement rate of interest from the date of Default.

23.2.3. Termination of Service

The Board may elect: (1) to terminate water deliveries to the Defaulting Party until the Event of Default is cured, if the Defaulting Party has other sources of water sufficient to meet Non-peak Season average daily demands, or (2) reduce water deliveries so that the Intake Facilities provides only enough water to meet Non-peak Season average daily demands when combined with the Defaulting Party's other sources.

23.2.4. Expulsion

In cases of repeated Defaults by the Defaulting Party, the Board may expel the Defaulting Party from the Commission and require the Defaulting Party to sell their Capacity ownership in the Intake Facilities. The removed Defaulting Party may ask to be a wholesale finished water supply purchaser from either Water Treatment Plant.

23.2.5. Litigation

Subject to Section 22 and 23, if the Event of Default is not cured or the

Board imposed Remedies are not complied with and the Dispute Resolution process has been waived or unsuccessful, any Party may file a lawsuit and seek available remedies under Oregon law.

23.3. Suspension of Legal Remedies Imposed by the Board

A Default may be addressed using the Dispute Resolution process described in Section 25. If Dispute Resolution has been requested, then the Remedy provisions of Section 23 will be suspended until the Dispute Resolution process is exhausted. Notwithstanding the foregoing, if the Default is of a nature that it poses a health risk to any user of the Intake Facilities or could cause damage to the Intake Facilities, Water Treatment Plants, or the Real Property, then the Board or any aggrieved Party may seek immediate equitable relief without waiting for initiation or completion of any Dispute Resolution.

24. Default by the Managing Agency

24.1. Generally

This Agreement obligates the Managing Agency to manage the business affairs of the Commission for the mutual benefit of all Parties to consistently deliver water from the Intake Facilities to their respective Water Treatment Plants. If the Managing Agency is also a Party and is alleged to be a Defaulting Party, a Supermajority of the remaining Board Members shall designate another Party to act as the facilitator for the Default. Based on the nature of the Default, the Board may also remove the Managing Agency from some or all Managing Agency duties pending Dispute Resolution, mediation, arbitration, or litigation, as the case may be. The following provisions shall apply to a Default by the Managing Agency, unless other Default provisions are contained in a separate Managing Agency contract, with the Managing Agency and are stated to control and supersede over these provisions.

24.2. **Notice of Default and Cure**

A written Notice of Default shall be delivered to the Managing Agency by the Board following a Supermajority vote of the remaining Members of the Board. The Managing Agency serves at the will of the Board. Therefore, the Notice may include a Notice of Termination of the Managing Agency, which termination may be immediate for acts or omissions such as gross negligence, malfeasance or dishonesty in financial practices, or at the end of a specified period of time set by the Board in the Notice. The Board must consider and provide a plan of transition if the Notice includes termination. If a Notice of Default with an opportunity to cure the Default is given, the Notice must specify the nature of the Default and provide a specified period in which to cure the Default or otherwise reasonably commence to cure the Default in a diligent manner. A reasonable cure period (“Cure Period”) shall be deemed to be 30 days unless another time for cure is set by the Board and contained in the Notice of Default. The Notice of Default may also include a requirement by the Board for the Managing Agency to engage in the Dispute Resolution process. A copy of the Notice of Default shall be delivered to all Parties. If the Managing Agency is a Party and the Board does not elect to terminate the Managing Agency, the Board may vote to temporarily remove the Managing Agency from some or all of its duties pending a cure of the Default.

24.3. **Event of Default**

The Managing Agency shall be deemed in Default of this Agreement if it fails to perform any obligation required to be performed by the Managing Agency under this Agreement or through a separate Managing Agency contract. An Event of Default shall be deemed to have occurred if the Managing Agency fails to cure the Default within the Cure Period designated in this Section 24.2, if any Cure Period

is allowed. If no Cure Period is given, then the Default shall be deemed to be an immediate Event of Default.

24.4. Remedies

If the Managing Agency commits an Event of Default, the Commission may seek any remedy available to it, at law or in equity. Such remedies include but are not limited to money damages, including restitution; specific performance; injunctive relief; and termination of the Managing Agency's contract. The Board, at its sole discretion, may enter into the Dispute Resolution process described in Section 25 if requested by the Managing Agency.

25. Dispute Resolution

This Agreement obligates the Parties to cooperate in the ownership and operation of the Intake Facilities for the mutual benefit of all Parties to consistently deliver water to their respective Water Treatment Plants. The Intake Facilities are the foundation of the other water system assets and Water Treatment Plants of the Parties. To that end, the Parties agree that each Party should bring forward issues regarding past performance or anticipated performance of obligations and duties at the earliest reasonable opportunity so that all Parties can proactively work toward solutions in an attempt to avoid a formal declaration of default. This Dispute Resolution process is provided to encourage informal resolution through negotiation among the Parties' staff, executives or elected officials before resorting to a formal process using mediation, arbitration, or litigation.

25.1. Notice of Dispute

Except in the case of a Default, any dispute shall be submitted in writing to the Management Committee. The Management Committee has 30 days from the date of notice to meet with the affected Parties to resolve the dispute. If the Management Committee does not resolve the dispute within the 30 day period, it shall be referred to mediation. In the case of a Default, either the Defaulting Party or the Board may

demand Dispute Resolution at any time during the Default process or within 10 days following imposition of any of the Remedies by the Board or the court, as set forth above. If Dispute Resolution is not requested during that time period, it shall be deemed waived and any aggrieved Party may proceed to litigation.

25.2. **Mediation**

A Party desiring mediation shall provide the other Parties with a written notice (“Request to Mediate”), which shall set forth the nature of the dispute. The Parties will thereafter cooperate in good faith to select the mediator within 14 days of either Party requesting mediation, and may adopt any procedural format that seems appropriate for the particular dispute. Mediation should be scheduled within 14 days of selection of the mediator, or as soon as possible, based on availability. In the event the Parties cannot agree on a mediator, the Parties will ask the Presiding Judge of Clackamas County Circuit Court to appoint a mediator. The mediator will then set the ground rules for the mediation. The Parties will share the mediation costs as agreed upon with the mediator. If a written settlement agreement is not reached by the Parties within 60 days from the date of the Request to Mediate, or such longer time frame as may be agreed upon, in writing, by the Parties, then the Parties may commence litigation. If the mediation fails the Parties may agree to binding arbitration. If all Parties do not agree to arbitrate, then any Party may seek legal relief through the Circuit Court of Clackamas County, or U.S. District Court if jurisdiction is available.

25.3. **Arbitration**

If the Parties agree to enter into binding arbitration, selection of the arbitrator, time frame for arbitration, and ground rules for arbitration will be agreed upon at that time. Any arbitrator or arbitrators selected must have a minimum of 10 years’ of municipal law experience, unless the Parties mutually agree, in writing, otherwise.

25.4. **Injunctive Relief and Specific Performance**

A Party may seek and obtain immediate equitable relief before or during the Dispute Resolution process and as described in Section 23.3.

25.5. **Attorney Fees**

Each Party shall bear its own legal fees and expert witness fees and all other costs in any Dispute Resolution process, including litigation.

26. Dissolution

The Parties may desire to dissolve the Commission. Dissolution of the Commission shall require an affirmative vote of each Party's governing body. Dissolution shall occur no later than five years from the date of the last affirmative vote to dissolve and no sooner than two years, unless the governing body of each Party agrees to a different deadline. If the Commission is not dissolved then any Party(ies) seeking dissolution may elect to terminate and withdraw as described in Section 19. If the Commission is dissolved, the Easement for the Intake Facilities in **Exhibit 1** will be automatically terminated.

26.1. **Plan of Dissolution**

The Managing Agency will develop a dissolution plan to wind up business affairs, to be reviewed and approved by the Management Committee before it is presented to each Party's respective governing body. The dissolution plan must provide for among other things: (1) the continued operation of the Intake Facilities while the dissolution plan is implemented; (2) an accounting of assets and liabilities; (3) provisions for the payment of debts and obligations, including assumption of future payment for ongoing debts and obligations along with appropriate indemnity provisions as the Parties mutually agree; (4) the creation of a reserve account for known, unforeseen, and contingent liabilities; (5) a plan for liquidation of the assets; and (6) a mechanism for distribution of asset proceeds and excess funds among the Parties in accordance with their ownership interest, following payment

of all liabilities and obligations related to the Intake Facilities.

26.2. Transfer of Capacity Ownership

The dissolution plan may provide for transfers of Capacity ownership, for cash or other consideration, from a Party that seeks complete divestiture of ownership to a Party who plans to remain and withdraw water from the Willamette River at the Intake Facilities. The dissolution plan must provide for appropriate documents to vest proportionate ownership as tenants in common for owners that remain in joint ownership of the Intake Facilities.

26.3. Disputes

Any dispute regarding dissolution, the dissolution plan, division of Capacity or transfer of Capacity shall be first subject to the Dispute Resolution process of Section 25 and, if not resolved in Dispute Resolution or mediation, then as determined by the Circuit Court of Clackamas County under ORS 190.020 (2).

27. General Provisions

27.1. Warranties and Representations

Each Party hereto warrants and represents that it has the legal authority to enter into this Agreement.

27.2. Ordinance of the Governing Body

Each Party to this Agreement hereby represents that it has undertaken or will undertake the necessary public procedures to approve an ordinance in accordance with ORS 190.085. The ordinance shall authorize the Party's representatives to the Board of the Commission to modify the Exhibits to this Agreement as provided in Section 27.6. The Parties further agree that they shall file with the Secretary of State, within 30 days after the Effective Date, the filings described in ORS 190.085(2).

27.3. **Insurance Requirements**

The insurance requirements and limits necessary for the operations of the Intake Facilities are described in **Exhibit 12** and shall be purchased and maintained at all times. The requirements will be reviewed by the Board annually, and modified when necessary per recommendations from the Managing Agency.

27.4. **Other Agreements**

Each Party warrants that entry into this Agreement will not constitute a default under any other agreement or covenant the Party may be bound to.

27.5. **Interpretation**

Unless a clear contrary intention appears: (a) reference to any person includes such person's successors and assigns but, if applicable, only if such successors and assigns are permitted by this Agreement, and reference to a person in a particular capacity excludes such person in any other capacity; (b) reference to any gender includes each other gender; (c) reference to any agreement (including this Agreement), document or instrument means such agreement, document or instrument as amended or modified and in effect from time to time in accordance with the terms thereof and, if applicable, the terms hereof; (d) reference to any Section, Schedule or Exhibit means such Section, Schedule or Exhibit to this Agreement, and references in any Section, Schedule, Exhibit or definition to any clause means such clause of such Section, Schedule, Exhibit or definition; (e) "hereunder," "hereof," "hereto," "herein," and words of similar import are references to this Agreement as a whole and not to any particular Section or other provision hereof; (f) relative to the determination of any period of time, "from" means "from and including", "to" means "to but excluding," and "through" means "through and including"; (g) "including" (and with correlative meaning "include")

means including without limiting the generality of any description preceding such term; (h) reference to any law (including statutes and ordinances) means such law as amended, modified, codified or reenacted, in whole or in part, and in effect from time to time, including rules and regulations promulgated thereunder; and reference to a singular number or person may include the plural number or person, and the plural number or person the singular.

27.6. **Exhibits**

The Parties agree that the Exhibits to this Agreement may be modified or amended by the Commission without other modification or amendment to this Agreement and without approval by the governing body of each Party. Upon execution of this Agreement, the Parties have agreed to include **Exhibits 1 through 13**, attached hereto and incorporated by reference. The purpose and intent of specific exhibits are set forth in other parts of this Agreement. Exhibits consisting of other agreements or contracts among other Parties to this Agreement, or with outside parties, may only be modified by consent of all of those named Parties/parties to those other agreements or contracts and not by the Commission without the consent of those other Parties/parties.

27.7. **Existing Agreements**

Existing Agreements between some or all of the Parties that affect or are affected by the Intake Facilities that are the subject of this Agreement are identified in **Exhibit 13**. These related agreements are not superseded or modified by this Agreement. Nothing in this Agreement shall be construed to require any alteration or modification of any other Existing Agreement. Specifically, the duration of this Agreement does not alter or extend the term of the Ground Lease.

27.8. **Periodic Review**

Exhibits shall be reviewed at least annually by the Board. Exhibits must be updated by resolution of the Board when ownership percentages change, new or expanded Capacity is placed in service, a new Party joins, an existing Party withdraws, or one or more Party(ies) purchases or sells an interest in the Intake Facilities.

27.9. **Severability**

Should any provision of this Agreement be rendered invalid by a court of competent jurisdiction or arbitrator with authority to render a provision invalid, it is agreed that every other part of the Agreement shall remain in full force and effect.

27.10. **No Joint and Several Liability**

Each Party to this Agreement assumes its own rights and obligations and does not assume the rights and obligations of any other Party.

27.11. **Counterparts**

This Agreement may be signed in one or more counterparts, and each counterpart shall be deemed to be an original instrument.

27.12. **Amendments and Modifications**

Except as provided in Section 27.6 for Exhibits, any modification or amendment to this Agreement requires unanimous approval of the Board and an affirmative vote of the governing bodies of all Parties. The amended Agreement must be signed by all Parties upon approval.

27.13. **Judicial Review and Attorney Fees**

This Agreement and its construction shall be governed by and construed in accordance with the laws of the State of Oregon without regard to principles of conflicts of law. Any claim, action, suit or proceeding between the Parties that arises from or relates to this Agreement shall be brought and conducted solely and

exclusively within the Circuit Court of Clackamas County for the State of Oregon. In any such claim, action, suit, or proceeding, the Parties shall bear their own fees and costs including attorney fees.

27.14. **Third Parties**

Except as expressly provided otherwise in this Agreement, the provisions of this Agreement are for the exclusive benefit of the Parties hereto and not for the benefit of any other persons, as third-party beneficiaries or otherwise, and this Agreement shall not be deemed to have conferred any rights, express or implied, upon any person not a Party to this Agreement.

27.15. **Non-Waiver**

Failure of any Party at any time to require performance of any provision of this Agreement shall not limit the Party's right to enforce the provision, nor shall any waiver of any breach of any provision be a waiver of any succeeding breach of the provision or a waiver of the provision itself or any other provisions.

27.16. **Time of the Essence**

Time is of the essence of each and every term, covenant, and condition set forth in this Agreement.

27.17. **Further Assurances**

Each Party agrees that it will reasonably consider cooperation in the execution of other documents and/or performance of other action as may be reasonably requested by another Party to more effectively consummate or achieve the purposes or subject matter of this Agreement.

27.18. **Signing Authority**

Each person signing this Agreement on behalf of a Party hereby warrants actual authority to bind their respective Party.

TUALATIN VALLEY WATER DISTRICT

By:

Richard Burke, President

APPROVED AS TO FORM

By:

Clark Balfour, District Counsel

CITY OF SHERWOOD

By:

Lee Weislogel, Mayor

APPROVED AS TO FORM

By:

Josh Soper, City Attorney

CITY OF TIGARD

By:

John Cook, Mayor

APPROVED AS TO FORM

By:

Shelby Rihala, City Attorney

CITY OF WILSONVILLE

By:

Tim Knapp, Mayor

APPROVED AS TO FORM

By:

Barbara Jacobson, City Attorney

CITY OF HILLSBORO

By:

Michael Brown, City Manager

APPROVED AS TO FORM

By:

Christopher Crean, City Attorney

CITY OF BEAVERTON

By:

Dennis Doyle, Mayor

APPROVED AS TO FORM

By:

Peter Livingston, City Attorney

After recording, return to:
City of Wilsonville
Attn: Legal Department
29799 SW Town Center Loop East
Wilsonville OR 97070

INTAKE FACILITIES EASEMENT

KNOW ALL BY THESE PRESENTS, that the **City of Wilsonville**, a duly chartered home rule municipal government of the State of Oregon (“Grantor Wilsonville”), and **Tualatin Valley Water District**, a duly organized water supply district under Oregon Revised Statutes (ORS) Chapter 264 (“Grantor TVWD”) (hereinafter collectively referred to as “Grantor”), as the legal owners of that certain real property described below (“Property”), for the consideration hereinafter stated, do hereby grant and convey unto the **Willamette River Intake Facilities Commission**, an ORS Chapter 190 entity of the State of Oregon (hereinafter referred to as “Grantee”), a permanent Intake Facilities Easement (“Easement”), effective the ____ day of _____ 2018 (“Effective Date”), in, under, across, and along the full width and length of that certain land owned by Grantor (“Easement Area”) and legally described and depicted as follows:

See **Exhibit A**, Easement legal description, and **Exhibit B**, drawing of Easement Area showing Intake Facilities, attached hereto and incorporated by reference as if fully set forth herein.

The true and actual consideration paid for this Easement, stated in terms of dollars, is Zero Dollars, but consists of value given or promised, which is agreed by Grantor and Grantee to be whole and adequate consideration.

TO HAVE AND TO HOLD the above-described Easement unto said Grantee for the benefit of the Grantee, in accordance with the conditions and covenants as follows:

1. **Scope of Easement.** Pursuant to the terms of the Willamette Intake Facilities Intergovernmental Agreement, dated _____, 2018 (the “IGA”), this Easement grants to Grantee the right, privilege, and authority to access, construct, inspect, operate, maintain, repair, replace, and remove the Intake Facilities. Grantor, upon request of Grantee, will authorize reasonable temporary work areas outside of the permanent easement area for a reasonable time period required for Grantee to perform construction, maintenance, repair, or replacement of the Intake Facilities. As used herein, Intake Facilities means the existing or upgraded Intake Facilities used to withdraw and transmit water from the authorized diversion point in the Willamette River to the agreed System Separation Point between the Willamette River Water Treatment Plant and the Willamette Water Supply System Water Treatment Plant. The System Separation Point means that point shown where the Intake Facilities terminate and water from the caisson of the Intake Facilities is separated by pumps into untreated water pipes conveying water to the two above-referenced Plants. There will be items beyond the System Separation Point that are separately owned and are

not assets of Grantee but rather are some assets owned by Grantor and some assets owned by only certain of the Grantees, as depicted on Exhibit B. The Intake Facilities and the System Separation Point, as noted on **Exhibit B** are all Permanent Assets and can remain with the Easement Area. All of those assets are permitted and will remain within the Easement Area. Except those buildings or structures depicted on **Exhibit B**, and for existing structures or improvements already located within the Easement Area, including but not limited to the pedestrian bridge, no buildings or structures shall be constructed within the Easement Area that would materially impede access to Grantee's Intake Facilities. Grantor shall, however, continue to have full access to the Easement Area and use of the same as long as the use does not unreasonably interfere with the uses granted to Grantee herein. Any expansion of the Intake Facilities beyond those shown on **Exhibit B** will require written approval of Grantor and an amendment to this Easement. Attached hereto as **Exhibit C** is a copy of Pipeline Easement No. 22670-EA from the Division of State Lands (DSL) to Grantor City of Wilsonville for that area at or below the ordinary low water mark which allows for the current in-water facilities. As part of this Easement, Grantor Wilsonville allows Grantee to exercise Wilsonville's rights under this DSL Easement, provided Grantee complies with all provisions. Grantor and Grantee understand the DSL Easement may need to be amended, with such amendment subject to DSL approval, in order to accommodate the new Intake Facilities. Grantor Wilsonville will use good faith efforts to work with DSL to obtain any such amendment, if needed.

2. **Definitions.** Capitalized terms not defined herein are as defined in the IGA.

3. **Security.** Grantee acknowledges and agrees that the Easement Area is currently and must remain a secure area and that access to the Easement Area must be closely monitored by Grantor Wilsonville. Therefore, except in the case of an emergency, Grantee shall give Grantor Wilsonville at least a 24-hour notice (may be by email or telephone) that Grantee will be coming to the Easement Area. In all cases, Grantee must sign in at the Willamette River Water Treatment Plant administration building before entering the Easement Area. While on site, Grantee must follow the Willamette River Water Treatment Plant security protocol. The administration building is staffed 24 hours a day, seven days a week. If this staffing protocol should ever change, Grantee will be given another means of immediate access (after required notice) before any change is made. Grantee shall give as much notice as reasonably possible in the case of an emergency. If Grantee wishes to come on to the Easement Area for routine operations, maintenance, or inspection and has not given at least 24 hours' advance notice, Grantee may contact Grantor Wilsonville and ask permission to come onto the Easement Area with shorter notice. Grantor Wilsonville may deny any shorter request that would interfere or conflict with already planned operations of the Willamette River Water Treatment Plant.

4. **AS IS CONDITION.** Except for warranty of title, Grantor makes no other representations or warranties with regard to the condition or suitability of the Easement Area for Grantee's intended use. This disclaimer of any and all warranties, excepting warranty of title, includes, but is not limited to, the environmental condition of the Easement Area and adjacent lands. It is Grantee's sole responsibility to conduct environmental due diligence and remediation for the Easement Area and any required archeological studies, if applicable, prior to construction. If any environmental hazards are discovered within the Easement Area, Grantee will be solely responsible for clean-up and remediation unless Grantee can prove that a Hazardous Substance release was caused by Grantor after the Effective Date of this Easement. Grantor will not be responsible to Grantee for the clean-up or remediation of any pre-existing environmental hazards, releases, or contamination. Grantee shall also be responsible for any exacerbation by Grantee of

any Hazardous Substance release that was caused by either Grantor after the Effective Date, but only to the extent of the exacerbation as long as Grantee had not been made aware of the condition caused by Grantor after the Effective Date and prior to the action that caused the exacerbation. Grantor's limited post-Effective Date responsibility for any Hazardous Substance condition within the Easement Area will apply only to the Grantor who actually caused the Hazardous Substance release after the Effective Date, and not to the other member of the collective Grantor(s). As used herein, "Hazardous Substances" include, but are not necessarily limited to, any substance, material, or product defined or designated as hazardous, toxic, radioactive, or dangerous, regulated wastes or substances, or any other similar term in or under any Environmental Laws as now apply or may apply in the future.

5. **Damage and Restoration.** Grantee, upon the initial expansion and construction of the Intake Facilities, and upon each and every occasion that the same be occupied for inspection, repair, replacement, addition to, or removal, shall restore the Easement Area and any improvements disturbed by Grantee, including but not limited to the pedestrian ramp, if any, to the same or better condition and repair, unless Grantor mutually agrees to some other proposed condition. Grantee shall be responsible to follow all City of Wilsonville public works and permitting standards during construction and shall be liable for all repair and restoration of any damage caused by Grantee's use of or operations within the Easement Area. Grantee shall also be liable to reimburse Grantor for any damage to Grantor's adjoining property caused by Grantee's construction or operations. Grantee shall have no obligation, however, to restore any building or structure placed within the Easement Area in violation of **Paragraph 1**.

6. **Relocation.** Grantor, or any one of them, may request relocation of the Easement Area and Intake Facilities impacted thereby, provided that such request for relocation is subject to written approval by Grantee, which approval shall not be unreasonably withheld or delayed. If requested by one Grantor, the other Grantor must also approve the requested relocation, in writing. If approved, the cost of relocation shall be at the requesting Grantor's sole expense.

7. **Duration of Easement.** This Easement begins on the Effective Date and will remain in place for as long as the Intake Facilities are used to transmit water to Grantee's water treatment plants for public consumption. Nothing contained herein, however, including duration, shall be construed in any way to alter or extend the term of the Ground Lease (wherein Grantor Wilsonville is the lessor) for the water pipeline currently used to convey water from the Intake Facilities to the Willamette Water Supply System Water Treatment Plant. If the Ground Lease is terminated, it will be incumbent upon Grantee to find another route to move the water from the Intake Facilities to its destination.

8. **Abandonment.** If the Intake Facilities are not used for a period of two years by Grantee, this Easement shall be deemed abandoned unless such lack of use is due to damage, destruction, reconstruction, or another event that temporarily prevents use by Grantee, and Grantee has made Grantor aware of the interruption in use and is exercising good faith to restore use. Notwithstanding the foregoing, if the Easement is not used for a period of seven years or longer, it will be deemed abandoned and this Easement will terminate. A delay in completion of construction of the Willamette Water Supply System Water Treatment Plant will not be considered an abandonment if longer than two years, as long as the construction is ongoing.

9. **Insurance.** Grantee will maintain and abide by the insurance requirements set forth in the IGA and will name Grantor as additional insureds with respect to this Easement. In addition, during construction activities and any time Hazardous Substances are being used within the Easement Area, other than in small quantities as generally needed for landscaping or as cleaning supplies, Grantee or Grantee's contractor shall carry full environmental coverage, including sudden and accidental and gradual release pollution liability coverage that will cover, among other things, environmental damage, any spillage of chemicals, fuels, oils, lubricants, de-icing, anti-freeze, or other hazardous materials, or disturbance of any Hazardous Substances during the performance of any work on the pipeline and/or other activities in the Easement Area or as a result of any pipe rupture, leakage, or other failure, written on an "occurrence" form policy. Grantee will be fully responsible for the cost of any clean-up of any released materials or disturbance, in accordance with Oregon Department of Environmental Quality ("DEQ") and Federal Environmental Protection Agency ("EPA") clean-up requirements. The amount of coverage will be agreed by Grantor and Grantee to be reasonable given the type of construction activity. Whatever the coverage might be, however, will not limit Grantee's liability or responsibility for any environmental damage claim or Hazardous Substances release. If said insurance is carried by Grantee's contractor, in lieu of Grantee, then Grantee must ensure that Grantor is named as an additional insured on the pollution policy in accordance with all requirements for naming Grantor as an additional insured. Nothing contained herein, however, shall be construed as a limitation on liability. Grantor shall maintain a direct right of action against Grantee and shall not be required to first seek relief through the insurance carrier or general contractor.

10. **Grantee's General Indemnity.** Grantee agrees to defend (using legal counsel reasonably acceptable to Grantor, taking into account insurance defense requirements), indemnify, reimburse, and hold harmless Grantor from and against any and all claims, demands, damages to person or property, including Grantor's own property, causes of action for injury or death, fines, penalties, expenses, costs, fees (including, but not limited to, attorney, accountant, paralegal, expert, and escrow fees), liabilities, losses, proceedings, and/or suits that may be imposed on or claimed against Grantor, in whole or in part, directly or indirectly, arising from or in any way connected with: (a) any act, omission, or negligence by Grantee or its partners, officers, directors, members, managers, agents, employees, invitees, contractors, subcontractors, and suppliers; (b) any use, occupation, management, or control of the Easement Area by Grantee, including, but not limited to, the sudden or accidental release of raw water that causes damage to person or property; (c) any condition created in or about the Easement Area by Grantee, including any accident, injury, or damage occurring on or about the Easement Area during the term of this Easement, unless caused by Grantor or a third party unrelated to Grantee; (d) any breach, violation, or nonperformance of any of Grantee's obligations under this Easement; or (e) any damage caused on or to the Easement Area during Grantee's use or occupancy thereof, unless caused by Grantor or a third party unrelated to Grantee. As used throughout this Easement, "Grantee" includes all of Grantee's partners, officers, directors, members, managers, agents, employees, invitees, contractors, consultants, and suppliers. This indemnity shall apply to any claim, however caused, or regardless of the legal grounds and basis, in which Grantor is named.

11. **Grantee's Environmental Indemnity.** Grantee will be solely responsible for and agrees to defend (using legal counsel reasonably acceptable to Grantor, taking into account insurance defense requirements), indemnify, and hold harmless Grantor from and against all environmental costs claimed against or assessed against Grantor arising, in whole or in part, from acts or omissions of Grantee (including Grantee's own employees, agents, contractors, or suppliers)

on or about the Easement Area. Grantee will be responsible to promptly and fully address and remediate any claims for natural resources damages, as directed by the agency assessing such damage claim. Notwithstanding the foregoing, Grantee will not be responsible for, and does not indemnify Grantor for, any actions of Grantor, including Grantor's own employees, agents, contractors, suppliers, or any other tenant of Grantor, that cause environmental damage or a violation of any environmental law within the Easement Area occurring after the Effective Date of this Easement.

12. **Condemnation.** If the Easement Area or any interest therein is taken as a result of the exercise of the right of eminent domain or under threat thereof (a "Taking"), this Easement will terminate with regard to the portion that is taken by condemnation authority. If Grantee determines that the portion of the Easement Area taken does not feasibly permit the continuation of the operation of the Intake Facilities, this Easement will terminate. The termination will be effective as of the date of the Taking. Any condemnation award relating to the land will be the property of Grantor. Grantee will not be entitled to any proceeds of any such real property award, except Grantee will be entitled to any compensation attributed by the condemning authority to Grantee's ownership interest in the Intake Facilities and relocation expense and loss or interruption of business.

13. **Legal Effect and Assignment.** This Easement runs with the land and shall be binding upon and inure to the benefit of the parties hereto and their respective successors and assigns.

14. **Defaults and Disputes.** Any legal action based on an alleged violation of this Easement will be brought in Clackamas County Circuit Court in the State of Oregon, and all remedies available at law or in equity will be available to the aggrieved Grantor(s) or Grantee. Except in those cases where either Grantor(s) or Grantee determines that equitable relief, including injunctive relief or specific performance, is needed, Grantor and Grantee agree to follow the mediation provision set forth in the IGA. In the case of equitable relief, either Grantor or Grantee may apply for immediate relief from the Court.

15. **Legal Action/Attorney Fees.** If a suit, action, or other proceeding of any nature whatsoever (including any proceeding under the U.S. Bankruptcy Code) is instituted in connection with any controversy arising out of this Easement or to interpret or enforce any rights or obligations hereunder, the prevailing party shall be entitled to recover attorney, paralegal, accountant, and other expert fees and all other fees, costs, and expenses actually incurred and reasonably necessary in connection therewith, as determined by the court or body at trial or on any appeal or review, in addition to all other amounts provided by law. Payment of all such fees shall also apply to any administrative proceeding, trial, and/or any appeal or petition for review. This attorney fee provision will not apply to mediation proceedings conducted pursuant to the IGA.

16. **Governing Law.** This Easement will be governed in accordance with the laws of the State of Oregon.

17. **Nonwaiver.** Any failure to enforce any provision of this Easement will not be deemed a waiver of the right to enforce that provision or any other provision of this Easement.

18. **Severability.** If any provision of this Easement is found to be void or unenforceable, it is the intent of the parties that the rest of the Easement shall remain in full force and effect, to the greatest extent allowed by law.

19. **Modification.** This Easement may not be modified unless signed by Grantor and Grantee and the modification is recorded.

20. **Time of the Essence.** Time is of the essence in performance of this Easement.

21. **Recording.** The fully executed original of this Easement shall be duly recorded in the Deed Records of Clackamas County, Oregon.

22. **Notices.** Any notice required or permitted under this Easement shall be in writing and shall be given when actually delivered in person or 48 hours after having been deposited in the United States mail as certified or registered mail, addressed to the addresses set forth below, or to such other address as one party may indicate by written notice to the other party.

To Grantor Wilsonville: City of Wilsonville
 Attn: Finance Director
 29799 SW Town Center Loop East
 Wilsonville, OR 97070

 with copy to: Wilsonville City Attorney
 29799 SW Town Center Loop East
 Wilsonville, OR 97070

To Grantor TVWD: Tualatin Valley Water District
 Attn: Chief Executive Officer
 1850 SW 170th Avenue
 Beaverton, OR 97003

 with copy to: District Counsel
 1850 SW 170th Avenue
 Beaverton, OR 97003

To Grantee: Willamette River Intake Facilities Commission
 Attn: Managing Agency
 1850 SW 170th Avenue
 Beaverton, OR 97003

[Signatures on following pages]

23. **Authority.** The individuals executing this Easement on behalf of Grantor and Grantee each represent and warrant that he/she has the full power and authority to do so on behalf of the respective party and to bind said party to the terms of this Easement.

IN WITNESS WHEREOF, the undersigned have executed this Easement effective as of the date first above written.

GRANTOR WILSONVILLE:

CITY OF WILSONVILLE

APPROVED AS TO LEGAL FORM:

By: _____
Bryan Cosgrove
As Its: City Manager

Barbara A. Jacobson, City Attorney

STATE OF OREGON)
) ss.
County of Clackamas)

This instrument was acknowledged before me on _____, 2018, by Bryan Cosgrove, who personally appeared before me, was identified by satisfactory evidence, and acknowledged that he executed the instrument in his authorized capacity as the City Manager of the City of Wilsonville, a municipal corporation of the State of Oregon, to be the free and voluntary act of such party for the uses and purposes mentioned in the instrument.

Notary Public – State of Oregon

[Signatures continued on following pages]

GRANTOR TVWD:

TUALATIN VALLEY WATER DISTRICT

APPROVED AS TO LEGAL FORM:

By: _____
Mark Knudson, P.E.
As Its: Chief Executive Officer

Clark Balfour, Counsel

STATE OF OREGON)
) ss.
County of Washington)

This instrument was acknowledged before me on _____, 2018, by Mark Knudson, P.E., who personally appeared before me, was identified by satisfactory evidence, and acknowledged that he executed the instrument in his authorized capacity as the Chief Executive Officer of Tualatin Valley Water District, a water supply district organized under ORS Chapter 264, to be the free and voluntary act of such party for the uses and purposes mentioned in the instrument.

Notary Public – State of Oregon

[Signatures continued on following pages]

ACCEPTED BY:

GRANTEE:

TUALATIN VALLEY WATER DISTRICT

By: _____
Richard Schmidt
As Its: Board President

STATE OF OREGON)
) ss.
County of Washington)

This instrument was acknowledged before me on _____, 2018, by Richard Schmidt, who personally appeared before me, was identified by satisfactory evidence, and acknowledged that he executed the instrument in his authorized capacity as the Board President of the Tualatin Valley Water District, a water supply district organized under ORS Chapter 264, to be the free and voluntary act of such party for the uses and purposes mentioned in the instrument.

Notary Public – State of Oregon

APPROVED AS TO FORM:

Clark Balfour, Counsel

[Signatures continued on following pages]

ACCEPTED BY:

GRANTEE:

CITY OF BEAVERTON

By: _____
Dennis Doyle
As Its: Mayor

STATE OF OREGON)
) ss.
County of Washington)

This instrument was acknowledged before me on _____, 2018, by Dennis Doyle, who personally appeared before me, was identified by satisfactory evidence, and acknowledged that he executed the instrument in his authorized capacity as the Mayor of the City of Beaverton, to be the free and voluntary act of such party for the uses and purposes mentioned in the instrument.

Notary Public – State of Oregon

APPROVED AS TO FORM:

Peter Livingston, City Attorney

[Signatures continued on following pages]

ACCEPTED BY:

GRANTEE:

CITY OF HILLSBORO

By: _____
Michael Brown
As Its: City Manager

STATE OF OREGON)
) ss.
County of Washington)

This instrument was acknowledged before me on _____, 2018, by Michael Bropwn, who personally appeared before me, was identified by satisfactory evidence, and acknowledged that he executed the instrument in his authorized capacity as the City Manager of the City of Hillsboro, to be the free and voluntary act of such party for the uses and purposes mentioned in the instrument.

Notary Public – State of Oregon

APPROVED AS TO FORM:

Christopher Crean, City Attorney

[Signatures continued on following pages]

ACCEPTED BY:

GRANTEE:

CITY OF SHERWOOD

By: _____
Krisanna Clark
As Its: Mayor

STATE OF OREGON)
) ss.
County of Washington)

This instrument was acknowledged before me on _____, 2018, by Krisanna Clark, who personally appeared before me, was identified by satisfactory evidence, and acknowledged that she executed the instrument in her authorized capacity as the Mayor of the City of Sherwood, to be the free and voluntary act of such party for the uses and purposes mentioned in the instrument.

Notary Public – State of Oregon

APPROVED AS TO FORM:

Josh Soper, City Attorney

[Signatures continued on following pages]

ACCEPTED BY:

GRANTEE:

CITY OF TIGARD

By: _____
John Cook
As Its: Mayor

STATE OF OREGON)
) ss.
County of Washington)

This instrument was acknowledged before me on _____, 2018, by John Cook, who personally appeared before me, was identified by satisfactory evidence, and acknowledged that he executed the instrument in his authorized capacity as the Mayor of the City of Tigard, to be the free and voluntary act of such party for the uses and purposes mentioned in the instrument.

Notary Public – State of Oregon

APPROVED AS TO FORM:

Shelby Rihala, City Attorney

[Signatures continued on following page]

ACCEPTED BY:

GRANTEE:

CITY OF WILSONVILLE

By: _____
Tim Knapp
As Its: Mayor

STATE OF OREGON)
) ss.
County of Clackamas)

This instrument was acknowledged before me on _____, 2018, by Tim Knapp, who personally appeared before me, was identified by satisfactory evidence, and acknowledged that he executed the instrument in his authorized capacity as the Mayor of the City of Wilsonville, to be the free and voluntary act of such party for the uses and purposes mentioned in the instrument.

Notary Public – State of Oregon

APPROVED AS TO FORM:

Barbara A. Jacobson, City Attorney

APPROVED AS TO LEGAL DESCRIPTION:

Nancy J.T. Kraushaar, P.E., City Engineer
City of Wilsonville, Oregon

EXHIBIT A

PLACEHOLDER FOR LEGAL DESCRIPTION

To be completed at a later date

EXHIBIT B

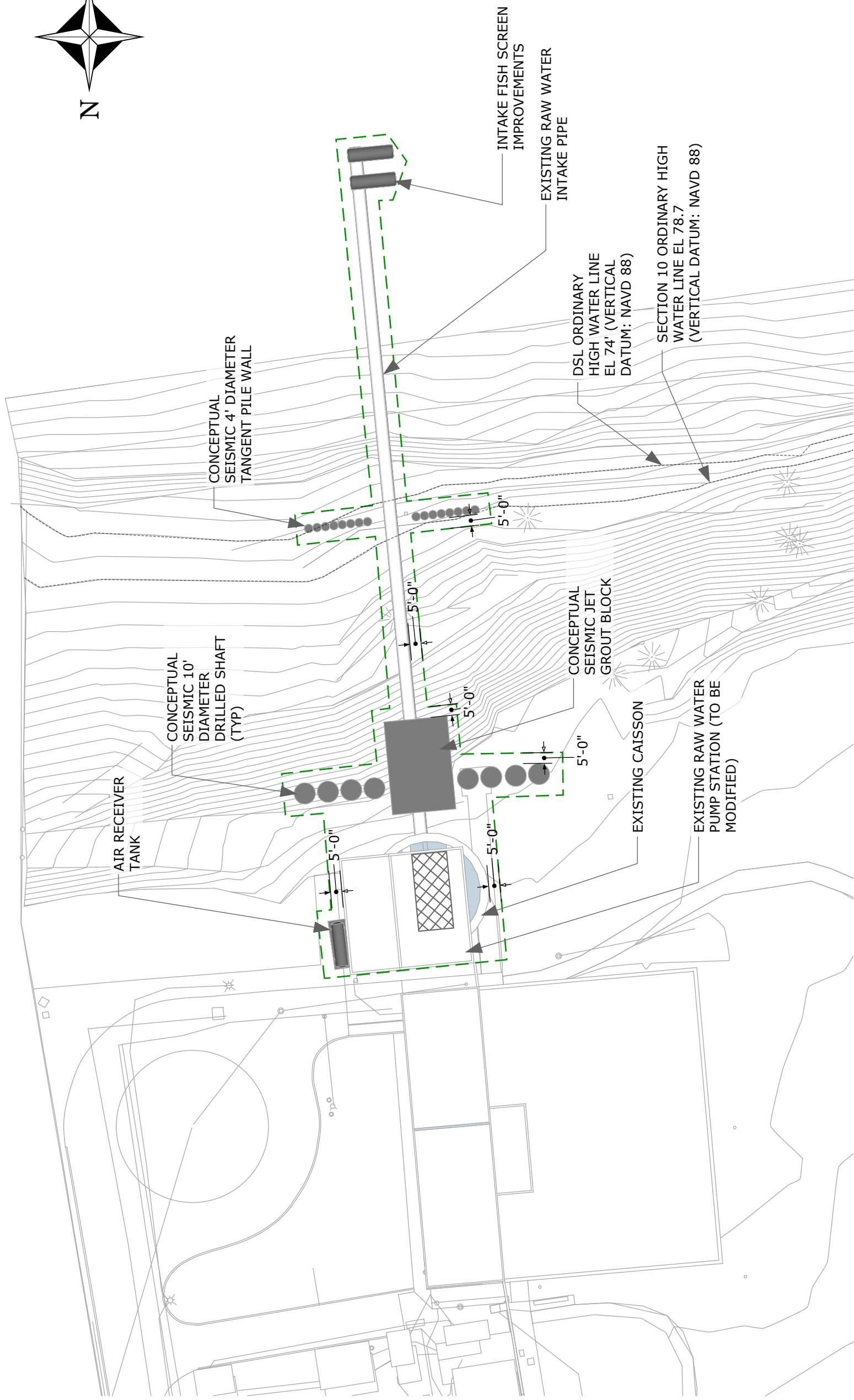

- EASEMENT
- EXISTING INFRASTRUCTURE
- NEW WILLAMETTE INTAKE FACILITIES INFRASTRUCTURE
- SYSTEM SEPARATION AREA

NOTES:
 1) EXHIBIT B IS A GENERAL LAYOUT DESCRIPTION BASED ON PRELIMINARY DESIGN CONCEPTS, BUT IS SUBJECT TO FINAL APPROVAL AT THE TIME EXHIBIT A IS GENERATED AND APPROVED.
 2) THE SYSTEM SEPARATION POINT IS LOCATED AT THE POINT WITHIN SYSTEM SEPARATION AREA THAT THE RAW WATER ENTERS THE RAW WATER PUMPS.
 3) THERE ARE ITEMS SUCH AS PUMPS AND ASSOCIATED MECHANICAL AND ELECTRICAL EQUIPMENT THAT ARE LOCATED WITHIN THE SYSTEM SEPARATION AREA THAT ARE NOT PART OF THE WILLAMETTE INTAKE FACILITIES EASEMENT.

**EXHIBIT B
 WILLAMETTE INTAKE
 FACILITIES EASEMENT**

JANUARY 2018

scale:

50'

**STATE OF OREGON
Division of State Lands**

PIPELINE EASEMENT NO. 22670-EA

The STATE OF OREGON, by and through its Division of State Lands, GRANTOR, for and in consideration of Two Hundred and Fifty Dollars and no cent (\$250.00), hereby grants to City of Wilsonville, GRANTEE, an easement and right to construct, maintain, operate and replace a water intake structure and pipeline in, over, upon, and across the State-owned submerged and submersible land of the Willamette River, in Clackamas County, Oregon, described as follows:

That portion of the following described land being below the Ordinary Low Water line as defined by elevation 55.0 feet above mean sea level, NGVD 1929, and being described as follows:

A strip of land, variable in width located within the Southwest one-quarter of Section 23, Township 3 South, Range 1 West, Willamette Meridian, City of Wilsonville, Clackamas County, Oregon. The centerline of said strip being described as commencing at the Northwest corner of said Section 23, Township 3 South, Range 1 West, Willamette Meridian, from which the North one-quarter corner of said Section 23 bears South 88°24'47" East, a distance of 2631.38 feet;

thence South 07°32'58" East, a distance of 3081.79 feet to the TRUE POINT OF BEGINNING;

thence South 03°04'44" East, a distance of 230 feet more or less to the said Ordinary Low Water line;

thence continuing South 03°04'44" East, a distance of 104.20 feet to the terminus of said centerline.

The width of said strip East of said centerline being 12 feet measured at right angles to said centerline from the point of beginning to its terminus. The width of said strip West of said centerline being 12 feet measured at right angles to said centerline from the point of beginning to a point 28 feet from its terminus; varying in width by straight line from 12 feet at 28 feet from the terminus to 17 feet at 14 feet from its terminus; varying in width by straight line from 17 feet at 14 feet from its terminus to 12 feet at the terminus. Said strip of land encompassing 2,571 square feet or 0.06 acres, more or less, and as shown on the attached Exhibit "A".

TO HAVE AND TO HOLD the same unto GRANTEE for 40 years, subject to the following conditions:

- 1. Construction in navigable waters shall conform to standards and specifications set by the U.S. Army Corps of Engineers or the U.S. Coast Guard for this Project.**
- 2. The bed and banks of the waterway shall be restored to a condition acceptable to the GRANTOR as soon as construction or maintenance is completed.**
- 3. Any blasting which may be necessary in the construction of the pipeline shall be performed according to the laws of the State.**
- 4. GRANTOR reserves the right to lease or otherwise utilize the State-owned lands within the granted area hereinabove described in a manner and for uses that will not be incompatible with the primary use for which this easement is granted.**
- 5. GRANTOR shall have the right to stop operation of the pipeline for noncompliance with the conditions of this easement or any lawful requirement by a regulatory agency of this State.**
- 6. GRANTEE agrees to defend and hold GRANTOR harmless from any and all claims suffered or alleged to be suffered on the premises. Further, GRANTEE shall be responsible for the payment of any fines or penalties charged against the premises as a result of GRANTEE's action in not complying with laws or regulations affecting the premises.**
- 7. If the facility for which this easement is granted is not used for a period of five (5) consecutive years, this easement may be terminated by written notice from GRANTOR to GRANTEE at its last known address. Upon termination, GRANTEE will have 90 days to remove the pipeline and appurtenances from the State-owned lands.**
- 8. Nothing in this document may be construed as permission, except during construction or maintenance periods, to GRANTEE to interfere with navigation or reduce the public's rights to the free and unimpeded use of the navigable waters of the State of Oregon within the boundaries of this easement; provided, however, that to the extent necessary to facilitate construction and maintenance of these facilities, GRANTEE may so interfere, but shall keep such interference to an absolute minimum.**
- 9. GRANTEE shall pay all assessments that may be legally charged on public lands which are levied against the property subject to this easement, whether or not such assessments have been levied against the leasehold or STATE by the assessing agency.**
- 10. GRANTEE shall use the property subject to this easement only in a manner, or for such purposes, that assure fair and nondiscriminatory treatment of all persons**

without respect to race, creed, color, religion, handicap, disability, age, gender or national origin.

This easement does not convey an estate in fee simple of the lands used for a right-of-way. This grant is for an easement only, and title remains in the State of Oregon.

WITNESS the seal of the Division of State Lands affixed this 13th day of July, 20 00.



STATE OF OREGON, acting by and through its Division of State Lands.

Stephen J. Purchase
Stephen J. Purchase

STATE OF Oregon)
) ss
County of Marion)

The foregoing instrument was acknowledged before me this 15th day of July, 2000, by Stephen J. Purchase, the Assistant Director (title) of the Division of State Lands.

Beth Smith
Signature
My Commission Expires 9/12, 2003

J:\Attachment\Aves\LASIEA Easements\22670-EA.doc



EXHIBIT TO ACCOMPANY DESCRIPTION

'A'

Water Intake Easement

SW 1/4, Section 23, Township 3 South, Range 1 West,
Willamette Meridian, City of Wilsonville, Clackamas County, Oregon

SECTION
CORNER

107

15 1/4
23 2/3

X = 7614299.82
Y = 604850.52

S 88° 24' 47" E

2631.38'

14

X = 7616930.19
Y = 604777.65

23

ONE-QUARTER
CORNER

EA-22670

Prepared for:

The CITY of WILSONVILLE

TRUE POINT
OF BEGINNING

3081.79'

S 07° 32' 58" E

1

X = 7614704.71
Y = 601795.45



Scale: 1" = 50'

AREA ABOVE
ELEVATION 55 FEET

12' 12"

S 03° 04' 14" E
230.00'

BEARINGS ARE BASED ON OREGON
COORDINATE SYSTEM, NORTH ZONE
PRIVATE SURVEY NUMBER 25005
CLACKAMAS COUNTY SURVEY RECORDS

ORDINARY LOW WATER LINE
AT ELEVATION 55 FEET ABOVE
MEAN SEA LEVEL, NGVD 1929

X = 7614717.06
Y = 601565.78

3

WILLAMETTE
RIVER



AREA COVERED
BY EASEMENT

3

S 03° 04' 14" E

104.30'

CENTERLINE
TERMINUS

13'

X = 7614722.66
Y = 601461.73

12'

12'

4

Prepared by:

**DEHAAS &
ASSOCIATES, INC.**

SUITE 300 - A.G.C. CENTER
9450 S.W. COMMERCE CIRCLE
WILSONVILLE, OREGON 97070
PHONE: (503) 682-2450
FAX: (503) 682-4018

Exhibit 2
Willamette Intake Facilities
Preliminary Design Drawings and
Layouts

New, Existing, and Modified WIF Project Components

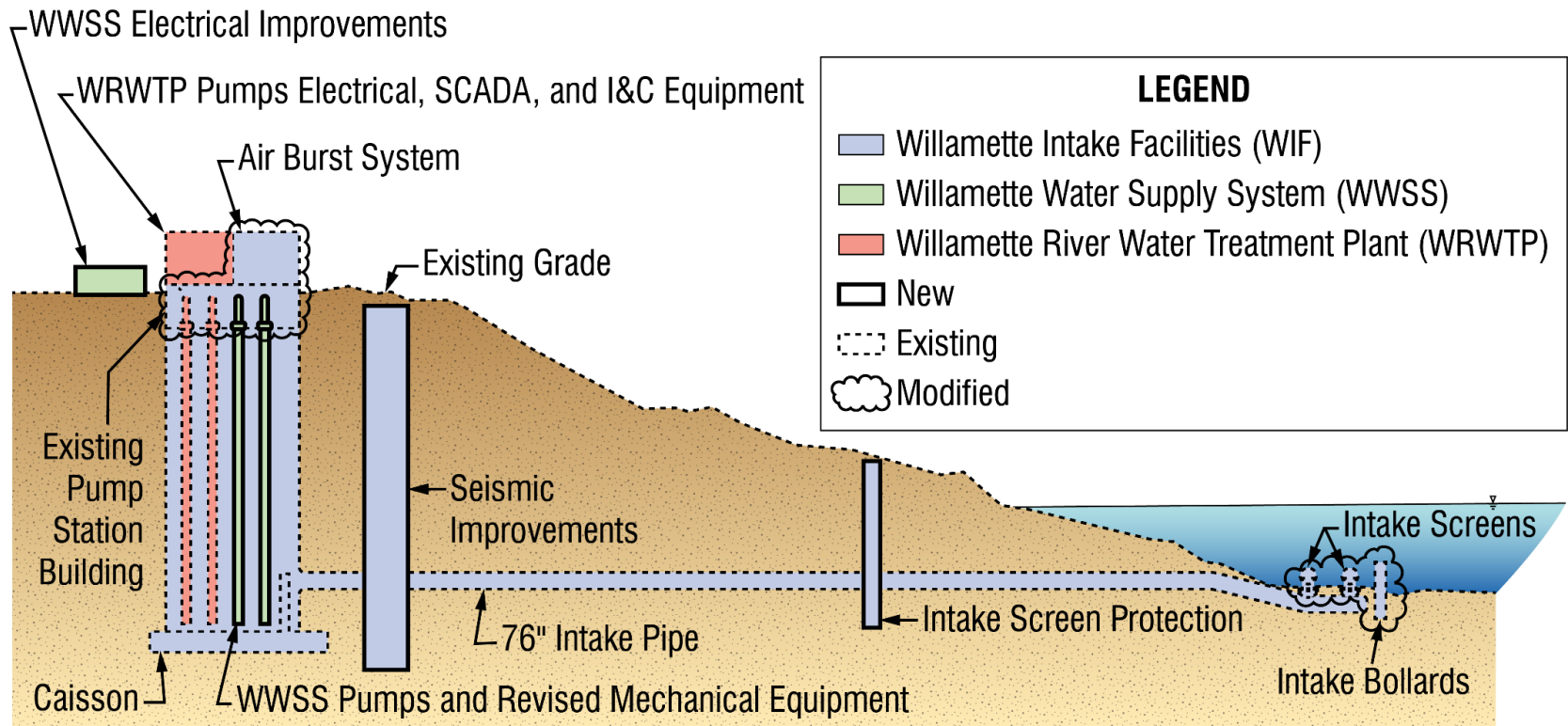

The System Separation Point is located where the raw water enters the raw water pumps.

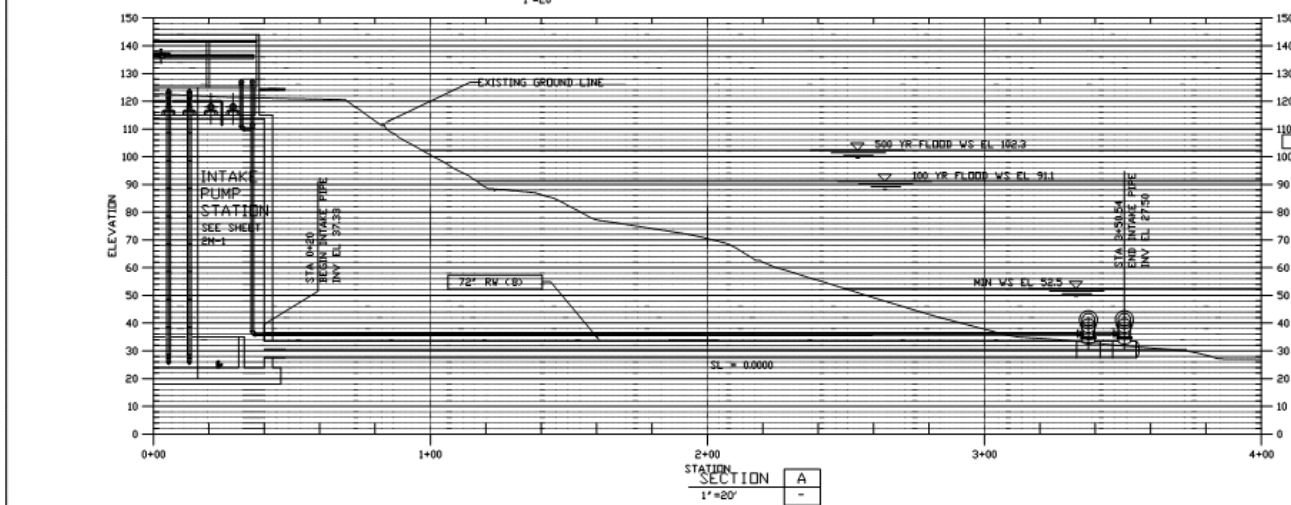
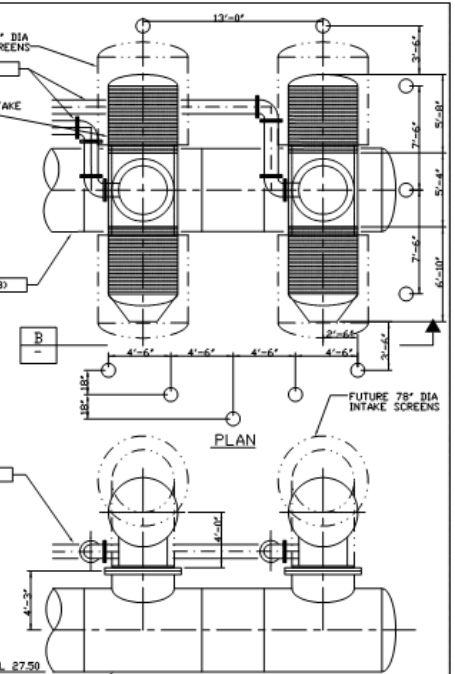
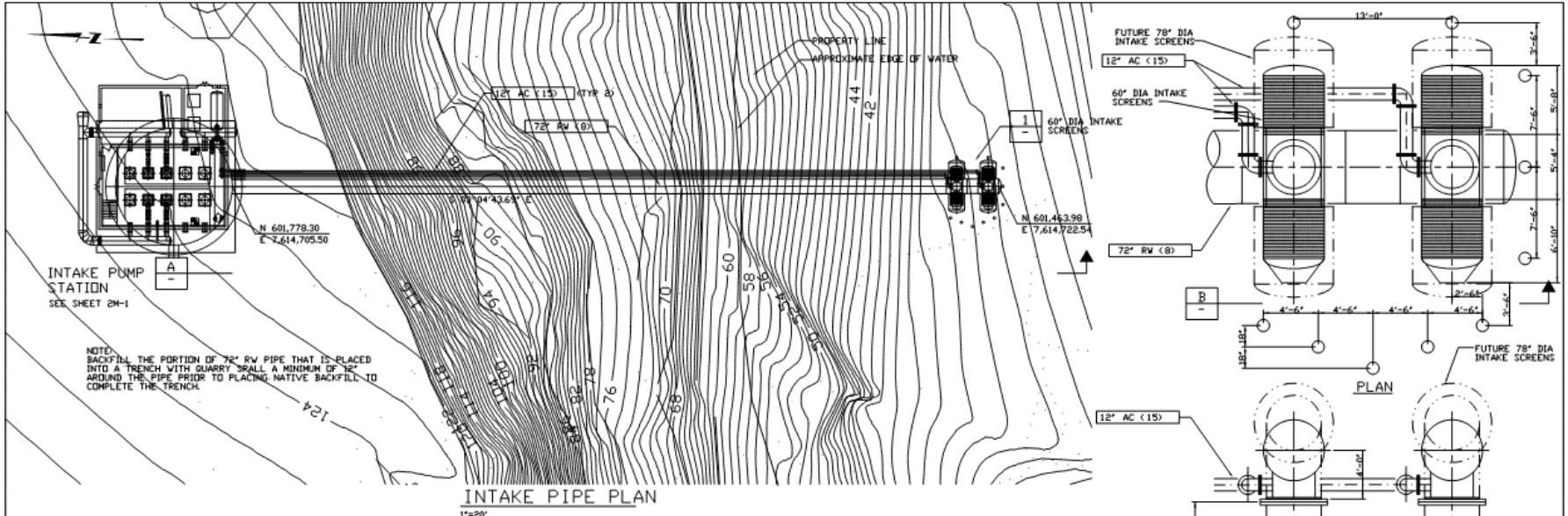

RECORD DRAWING

This record drawing has been prepared, entirely or in part on the basis of unverified information compiled and furnished by others to the preparer who is not responsible for any inaccuracies, errors or omissions which may have been incorporated into the document as a result

REV	DATE	BY	DESCRIPTION
1			RECORD DRAWING

SCALE	AS NOTED	WARNING	DESIGNED	SUBMITTED BY
0 1/2 1		F THIS BAR DOES NOT MEASURE IF THEN DRAWING IS NOT TO SCALE	D. PATRICK	
			CHECKED	

LICENSE NO.	DATE
LICENSE NO.	DATE

MONTGOMERY WATSON
 Portland, Oregon

City of
WILSONVILLE
 in OREGON

CITY OF WILSONVILLE
 VILLANETTE RIVER WATER TREATMENT PLANT
 INTAKE SCREENS AND
 PIPELINE PLAN AND SECTION

SHEET
C-22
 *

Exhibit 3
Willamette Intake Facilities
Capacity Ownership Allocations

Description:

Willamette Intake Facilities Capacity Ownership		
Entity	Capacity (mgd) (1)	Percent
Wilsonville	25.0	16.67%
Tualatin Valley Water District	59.1	39.40%
Sherwood (2)	9.7	6.47%
Tigard (3)	15.0	10.00%
Hillsboro (3)	36.2	24.13%
Beaverton (3)	5.0	3.33%
Total	150.00	100.00%

- (1) Estimated capacity which will be evaluated through additional physical hydraulic modeling.
- (2) Includes existing ownership interest with allocation of increased intake capacity to 150 mgd and estimated capacity to be purchased from TVWD.
- (3) Estimated capacity to be purchased by each entity from TVWD.

Willamette Intake Facilities – Asset Values at Original (2002) Cost of Construction*

Project Element	Wilsonville	TVWD	Sherwood	Total
Screening	\$ 207,147	\$ 466,082	\$ 51,787	\$ 725,016
Intake Pipe	\$ 228,029	\$ 1,083,139	\$ 57,007	\$ 1,368,175
Wetwell	\$ 364,847	\$ 1,733,021	\$ 91,212	\$ 2,189,079
Pump Station Building	\$ 233,834	\$ 1,110,709	\$ 58,458	\$ 1,403,001
Total	\$ 1,033,857	\$ 4,392,950	\$ 258,464	\$ 5,685,271

*Notes:

- (1) Original cost shares based on 2002 original construction costs and do not include allocation of program management costs.
- (2) Pumps, Electrical Wire & Conduit, Electrical Equipment and the Raw Water Pipeline from the caisson to the Willamette River Water Treatment Plant were included as part of the original cost of construction in 2002, but are not included here since those assets are not included in the Willamette Intake Facilities.

Methodology used to establish buy-in costs for each Party:

1. TVWD & Wilsonville identified TVWD's share of **Original Direct Cost** (2002) for each asset included in the purchase and sale
2. For each asset, added TVWD's share of **Program Costs** from original Wilsonville-TVWD construction (2002) to **Original Direct Cost** to establish **TVWD Original Cost**
3. Subtracted depreciation from **TVWD Original Cost** to establish **TVWD Book Value**
4. Added **TVWD Cost of Capital** (from 2002 to 2016 at 4% per year) to **TVWD Book Value** to establish **TVWD Asset Offer Price**
5. Added one-time Administrative Cost (3% of **Asset Offer Price**) to **TVWD Asset Offer Price** to establish **Buy-in Offer Price**
6. Calculated cost per MGD of **Buy-in Offer Price** based on TVWD available capacity of 59.7 MGD to establish **Buy-in Offer Unit Price**
7. For each asset being purchased by each Party, multiplied the **Buy-in Unit Price** times the capacity being purchased by the party to establish **Buy-in Offer Price** by Party by asset
8. For each party, totaled the Party's **Buy-in Offer Price** for all assets being purchased

Resulting Capacity and Cost of Purchase for WIF Assets Acquired from TVWD*

Acquired Capacity (MGD) from TVWD by Party by Asset								
Project Element	Wilsonville	TVWD	Sherwood	Tigard	Tualatin	Hillsboro	Beaverton	Total
Screening	0	0	0	0	0	0	0	0
Intake Pipe	0	0	3.45	15	0	36.2	5	59.65
Wetwell	0	0	3.45	15	0	36.2	5	59.65
Pump Station Building	0	0	3.45	15	0	36.2	5	59.65
Cost of Purchase (\$) from TVWD by Party by Asset								
Project Element	Wilsonville	TVWD	Sherwood	Tigard	Tualatin	Hillsboro	Beaverton	Total
Screening	\$ -	\$ -	\$ -	\$ -	\$ -	\$ -	\$ -	\$ -
Intake Pipe	\$ -	\$ -	\$ 50,462	\$ 219,399	\$ -	\$ 529,482	\$ 73,133	\$ 872,476
Wetwell	\$ -	\$ -	\$ 80,739	\$ 351,038	\$ -	\$ 847,171	\$ 117,013	\$ 1,395,961
Pump Station Building	\$ -	\$ -	\$ 41,355	\$ 179,802	\$ -	\$ 433,923	\$ 59,934	\$ 715,014
Total	\$ -	\$ -	\$ 172,555	\$ 750,239	\$ -	\$ 1,810,577	\$ 250,080	\$ 2,983,451

*Notes:

1. Raw water Pumps, Electrical Wire & Conduit, Electrical Equipment, and Raw Water Pipeline are not WIF assets and transfers of Raw Water Pipeline capacity are covered under separate agreements.
2. Wilsonville acquired 5 MGD of capacity in existing Raw Water Pipeline to the WRWTP from TVWD under separate agreement.
3. Sherwood acquired 4.7 MGD of capacity in existing Raw Water Pipeline to the WRWTP from TVWD under a separate agreement.
4. Tigard will not acquire capacity in the existing Raw Water Pipeline to the WRWTP or the future WWSS at this time. Tigard will conduct planning in the future to determine if Tigard will use capacity from the WWSS system or from the WRWTP

system, in which case Tigard will need to obtain Raw Water Pipeline capacity from TVWD and/or capacity in the WWSS.

Willamette Intake Facilities Seismic and Facilities Improvements (1)		
Location	Year	Cost
Wilsonville		
Tualatin Valley Water District		
Sherwood		
Tigard		
Hillsboro		
Beaverton		
Total:		

(1) To be updated after project completion with actual design and construction costs.

Exhibit 4 Real Property

Description:

The Real Property currently owned by Wilsonville and TVWD upon which the Willamette Intake Facilities and appurtenances are located are described in Attachment 1, Real Property Legal Description and Map, and Attachment 2, Special Warranty Deed.

Order No: 216629

LEGAL DESCRIPTION**PARCEL I:**

Being a part of the R. V. Short Donation Land Claim in Township 3 South, Range 1 West, Willamette Meridian, in the County of Clackamas and State of Oregon, bounded and described as follows, to-wit:

Beginning at a point on the line between Sections 22 and 23, said township and range, 792.23 feet South 0°03' East of the Northwest corner of said Section 23; running thence South 0°03' East on said section line 604.99 feet to the Southwest corner of M.A. Holbrook Tract as recorded in Book 159, Page 546, Records of Deed for Clackamas County, Oregon; thence North 89°50' East 1239.0 feet along the South boundary of the said Holbrook Tract to the East line of the above mentioned Short DLC; thence North 0°17' West along the East boundary of the said Short DLC 545.7 feet to a point; thence North 87°25' West 1237.9 feet to the place of beginning.

EXCEPT the West 20 feet thereof conveyed for private roadway.

AND FURTHER EXCEPTING THEREFROM that portion included in Quit Claim Deed to Joe Bernert Towing Co., Inc. recorded December 29, 1987 as Recorder's Fee No. 87057703.

PARCEL II:

A tract of land in a portion of the Robert V. Short DLC No.46 located in the Northwest and Southwest one-quarters of Section 23, Township 3 South, Range 1 West of the Willamette Meridian, in the County of Clackamas and State of Oregon, described as follows:

Beginning at a point on the North line of said Section 23, that bears East a distance of 20.00 feet from the Northwest corner of said Section 23; thence South 0°03'00" East, parallel with and 20 feet Easterly of the West line of said Section 23, a distance of 1397.22 feet to an interior angle corner in the Northerly line of that tract of land conveyed to Hardy S. Young by Deed, described in and recorded under Fee Number 74-10618 Clackamas County Deed Records; thence North 89°51' East, along said Young's North line, a distance of 580.00 feet to a 5/8 inch iron rod at the Northwest corner of that tract of land conveyed as a Tract I to Joe Bernert Towing Company, Inc., in a contract recorded under Fee Number 75-9882, Deed Records; thence South 0°03' East, along the Westerly line of said Towing Company Tract, a distance of 220.00 feet to a 5/8 inch iron rod at the Northeast corner of that tract of land conveyed to Joe Bernert Towing Company, Inc., by a contract described in and recorded under Fee Number 90-2243, Deed Records; thence South 89°51' West, along the Northerly line of last said tract, a distance of 60.00 feet to a 5/8 inch iron rod; thence South 77°08'26" West, along last said Towing Company Tract, a distance of 492.25 feet to a 5/8 inch iron rod; thence South 0°03' East, along the Westerly line of last said tract, a distance of 141.69 feet to a 5/8 inch iron rod; thence South 49°54'37" East, along a Westerly line of last said tract, a distance of 659.97 feet to a 5/8 inch iron rod at an angle corner in said Westerly line; thence South 9°47'13" East, along said Westerly line, a distance of 747.37 feet to a 5/8 inch iron rod, being the South corner of said Fee Number 90-2243, said South corner being on the West line of said Tract I of Fee Number 75-9882; thence South 0°03' East, along the West line of said Tract I, a distance of 225.18 feet, more or less, to the South line of said Fee Number 74-10618; thence South 83°31'40" West, along the South line of said Fee Number 74-10618, a distance of 517.54 feet, more or less, to the mouth of a ravine; thence

Order No: 216629

LEGAL DESCRIPTION

South 77°46'41" West, continuing along the South line of Fee Number 74-10618, a distance of 79.72 feet to the Southwest corner thereof; thence North, along the Westerly line of said Fee Number 74-10618, a distance of 966.90 feet to a point; thence North 58°00' West, a distance of 117.48 feet to a point on the West line of said Section 23; thence North 0°03" West, along said West section line, a distance of 2299.44 feet to the Northwest corner of said Section 23; thence East a distance of 20.00 feet returning to the point of beginning.

PARCEL III:

TOGETHER WITH an easement for road and utility purposes over the following described parcel:

A tract of land situated in Section 23, Township 3 South, Range 1 West, of the Willamette Meridian, in the County of Clackamas and State of Oregon, being more particularly described as follows, to wit:

A strip of land 60.00 feet in width and heretofore known as the Industrial Way Road easement, the centerline intersection of said 60.00 foot strip of land with the centerline of Market Road No. 6 (also known as Wilsonville Road), which intersection is North 89°56' East along the centerline of Market Road No. 6, 1278.43 feet from the Northwest corner of said Section 23, Township 3 South, Range 1 West, of the Willamette Meridian, in the County of Clackamas and State of Oregon, from said place of beginning; thence leaving said centerline of Market Road No. 6, South 31°36' East along the centerline of said 60.00 foot strip of land 263.90 feet; thence South 17°48' East 64.49 feet; thence South 10°22' West, 145.34 feet to the intersection of the North line of the Bailey D.L.C. No. 45; the same point of intersection being South 89°55' East 163.15 feet from the Northwest corner of the Thomas Bailey D.L.C. No. 45; thence South 10°22' West 906.74 feet along the centerline of said 60.00 foot strip of land South to the point of intersection of said centerline with the West line of said Thomas Bailey D.L.C.

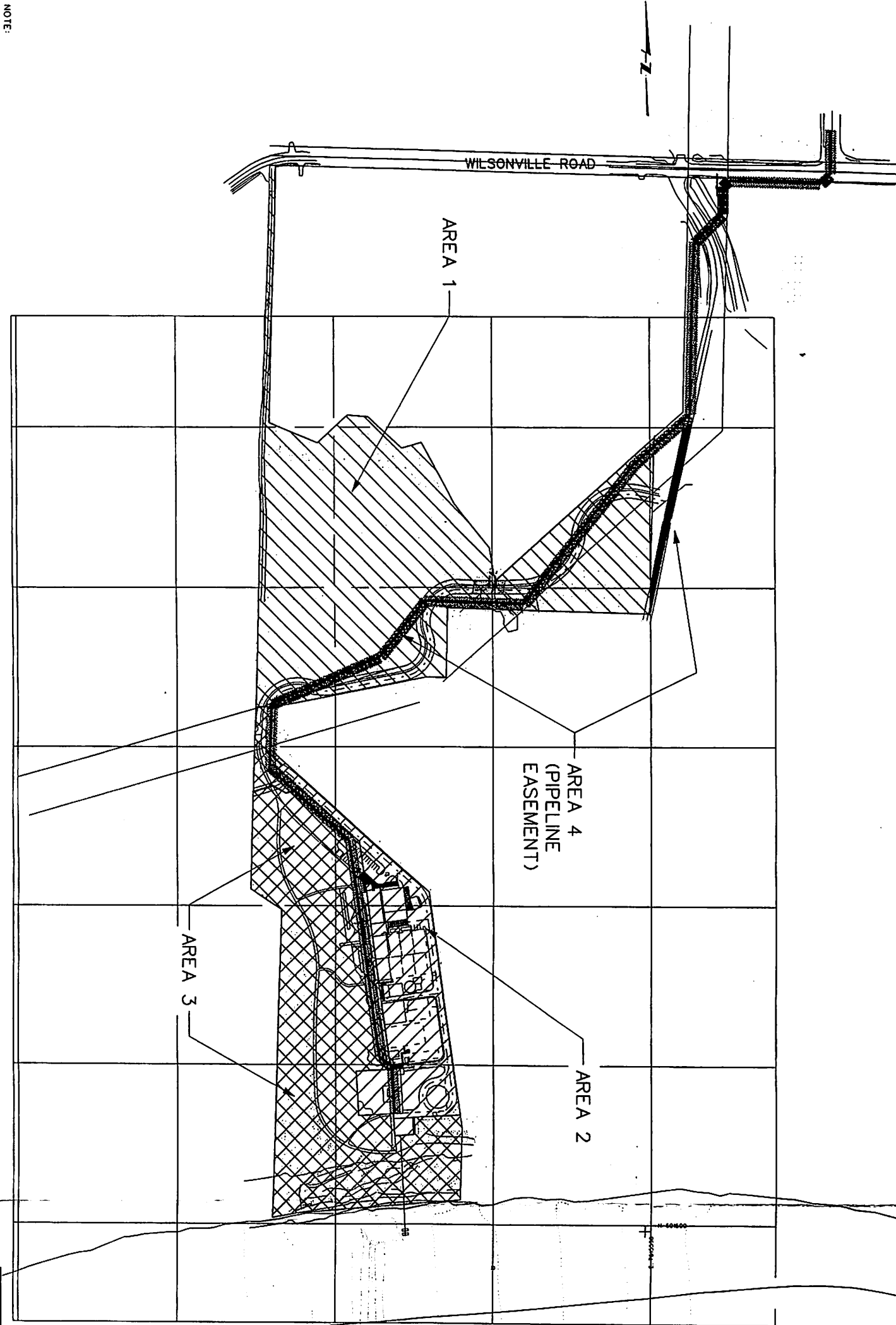

NOTE:
 AREA 4 - OFF-SITE LOCATION FOR ACCESS AND PIPELINE IS OWNED BY THE CITY WITHIN THE INDUSTRIAL WAY EASEMENT, BUT IS SHOWN NEARBY IN CONTEMPLATION OF A PROBABLE LOCATION ADJUSTMENT BY DEVELOPMENT REVIEW BOARD AND ACQUISITION FROM PROPERTY OWNERS.

CITY OF WILSONVILLE
 WILLAMETTE RIVER WATER TREATMENT PLANT

EXHIBIT B
 GENERAL AREA MAP

We certify this instrument to be a true
copy recorded 7/28/2000
Book _____, Page _____, For 2000-048871
Records of Clackamas County, Oregon.

CHICAGO TITLE INSURANCE COMPANY

By [Signature]

SPECIAL WARRANTY DEED

City of Wilsonville, an Oregon Municipal corporation, Grantor, grants, conveys and specially warrants to **Tualatin Valley Water District, a water supply district, Grantee,** an undivided forty-nine percent (49%) interest as tenant in common, and the City of Wilsonville reserves to itself the remaining fifty-one percent (51%) interest as tenant in common, in and to the following described real property free of encumbrances created or suffered by the Grantor except as specifically set forth herein, situated in Clackamas County, Oregon, to-wit:

Parcels I and II, together with Parcel III, an easement, as described in the attached Exhibit A and incorporated by reference herein.

The true consideration for this conveyance is \$1,291,350.00.

The said property is free of all encumbrances created or suffered by Grantor, except easements, access agreements, roadway agreements, and maintenance agreements of record, and changes (if any) in the location of the Willamette River and shall be subject to the following covenants to run with the land:

1. The above described real property is dedicated, conveyed and granted for domestic and municipal water supply purposes and such accessory uses as may be necessary and convenient thereto, together with the following purposes:

1.1 Area 1, which is the northern portion of the property as set forth in Exhibit B, attached hereto and incorporated herein, shall include an access road and bicycle and pedestrian access to Areas 2 and 3. The Grantor reserves Area 1 for park and recreational purposes at the sole risk and cost of Grantor; provided, however, upon one-year notice by either Grantor or Grantee to the other, park and recreation usage shall terminate to accommodate use for future domestic and municipal water supply facility capacity in excess of the 70 mgd facilities in Area 2, subject to required land use approval and such other governmental approvals as may be required. Nothing in the foregoing sentence is intended to limit or restrict the parties from agreeing to use the property in any manner in support of the Supply Facilities and/or such governmental regulations as may be imposed on the parties for the operation of up to a 70 mgd capacity plant.

After recording, return to:
City Recorder, City of Wilsonville
30000 SW Town Center Loop E.
Wilsonville, OR 97070

Until requested otherwise, send tax statements to:
No Change

- 1.2 Area 2 is that portion on the site which includes the multi-barrier treatment plant with expansion up to 70 mgd (the wall and area behind the wall) as set forth in Exhibit B.
 - 1.3 Area 3 is the "Meadow Area" and Water Feature as set forth on Exhibit B and is to be developed for passive recreational use and will have bicycle and pedestrian use and access. This public bicycle and pedestrian access will also extend to the Plant.
 - 1.4 Area 4 is the 70' access easement, together with such other property and/or easements necessary for the alignment of the access roadway from the property to Wilsonville Road and the water transmission line from the Treatment Plant to Wilsonville Road as set forth in Exhibit B. Thereafter, the transmission line will be in the Grantor's Wilsonville Road right-of-way until it joins the City's transmission system at or about Station 67⁺00^{+/-} of the Grantor's Kinsman Road right-of-way. The Grantor's Wilsonville Road and Kinsman Road right-of-ways are not intended to be conveyed to Grantee as part of this deed or otherwise.
2. Grantee's 49% ownership interest may be conveyed in whole or in part by Grantee, with prior approval by Grantor to the Willamette Water Supply Agency (WWSA) for a period of one year (365 days) from June 30, 2000, and thereafter without prior approval by Grantor; provided, however, WWSA's membership remains one of local governments and water districts. Neither Grantor nor Grantee shall convey to any person or entity which is not a local government or water district without the prior consent of the other. Each party's consent shall be based in its sole discretion on whether an allocation or conveyance to an entity other than a local government or water district is in the best interest of, in the case of Grantor, its citizens and, in the case of Grantee, its customers. Nothing in this paragraph is intended to prevent Grantee from conveying to Grantor or Grantor from conveying to Grantee its respective interest as the parties may agree in the future.
 3. Neither Grantor nor Grantee shall seek or obtain through any legal proceedings an administrative or judicial partition of the Property or sale of the Property in lieu of partition, without the prior written consent of the other. Paragraph 2 above is not intended or meant to create a partition of the Property and this paragraph on partition is not intended or meant to prevent an allocation and conveyance of Grantee's interest as set forth in paragraph 2 above.
 4. Nothing in the above covenants is intended to prevent a deletion, amendment, or modification of the above covenants if expressly agreed to by Grantor and Grantee, their respective successors in interest, if any, in writing and duly recorded.

Grantee has inspected the said property and accepts the condition of the said property as is.

This Deed fully satisfies paragraphs 2.1 and 2.2 of that certain Agreement Regarding Water Treatment Plant Design, Construction, Operation, and Property Ownership, which document is a matter of record and on file with both the Grantor and Grantee.

THIS INSTRUMENT WILL NOT ALLOW USE OF THE PROPERTY DESCRIBED IN THIS INSTRUMENT IN VIOLATION OF APPLICABLE LAND USE LAWS AND REGULATIONS. BEFORE SIGNING OR ACCEPTING THIS INSTRUMENT, THE PERSON ACQUIRING FEE TITLE TO THE PROPERTY SHOULD CHECK WITH THE APPROPRIATE CITY OR COUNTY PLANNING DEPARTMENT TO VERIFY APPROVED USES AND TO DETERMINE ANY LIMITS ON LAWSUITS AGAINST FARMING OR FOREST PRACTICES AS DEFINED IN ORS 30.930.

IN WITNESS WHEREOF, the Grantor has executed this instrument this 7th day of July, 2000.

GRANTOR: CITY OF WILSONVILLE

By *Charlotte Lehan*
Charlotte Lehan

Title: Mayor

ATTESTED TO:

By *Diane M. Pankonin*
Diane M. Pankonin
acting City Recorder

Date: July 7, 2000

STATE OF OREGON)
) ss
County of Clackamas)

On this 7th day of July, 2000, before me, a notary public in and for said County and State, personally appeared Charlotte Lehan, known to me to be the Mayor of the City of Wilsonville and whose name she subscribed to the within instrument and acknowledged that she executed the same for the purposes therein contained.

IN WITNESS WHEREOF, I have hereunto set my hand and official seal on the day and year above written.

Susan Marie Farnsworth
Notary Public for Oregon
My Commission Expires: March 12, 2003



EXHIBIT 5 - Water Rights Authorized for Use at Willamette Intake Facilities

Water Right Permits and Certificates Authorized by the Oregon Water Resources Department

Entity Name on Water Right	Application	Permit	Certificate	Transfer or Permit Amendment	Priority Date	Type of Beneficial Use	Authorized Rate (cfs)	Authorized Date for Completion	Conditions
Willamette River Water Coalition	S-50693	S-49240	N/A	T-10477	June 19, 1973	Municipal & Industrial	202.0	October 1, 2047	<ul style="list-style-type: none"> Measuring device required Fish screen required A 60-day waiting period is required between WMCP approval and diversion of water for the first diversion and each increment of "green light water" for each water supplier. WMCP provisions apply to additional future municipal water suppliers using water under permit under certain conditions. WRWC member Sherwood has access to up to 23 cfs based on last WMCP approval. TVWD has access to up to 80.1 cfs following approval of its most recent updated WMCP. Fish persistence conditions. Proportional reduction based on target flows and the portion of permit to which permittee has legal access. Reduction is capped at 20% during April, May and June.
City of Wilsonville	S-51780	S-46319	N/A	T-8444	March 27, 1974	Municipal	30.0	October 1, 2042	<ul style="list-style-type: none"> Measuring device required Fish screen required
City of Beaverton	S-87964	S-54940	N/A	-	March 11, 2014	Municipal	33.7	May 4, 2035	<ul style="list-style-type: none"> Measuring device and water use reporting are required Fish screen required Diversion of water is prohibited at times when the ODFW recommended flow targets at the Salem gage are not met.
City of Hillsboro	S-55010	S-55045	N/A	T-12512	December 6, 1976	Municipal	56	October 1, 2086	<ul style="list-style-type: none"> Willamette Intake Facilities added as a point of diversion through a permit amendment Conditions from permit amendment require measurement device and fish screen. Fish persistence conditions. Proportional reduction based on target flows and permit's maximum authorized rate; capped at 20% year-round. Approval of a WMCP is required to obtain access to water under the permit.

Exhibit 6 Organizational Structure

Description:

This Exhibit sets forth the Organizational Structure for the Willamette Intake Facilities Commission.

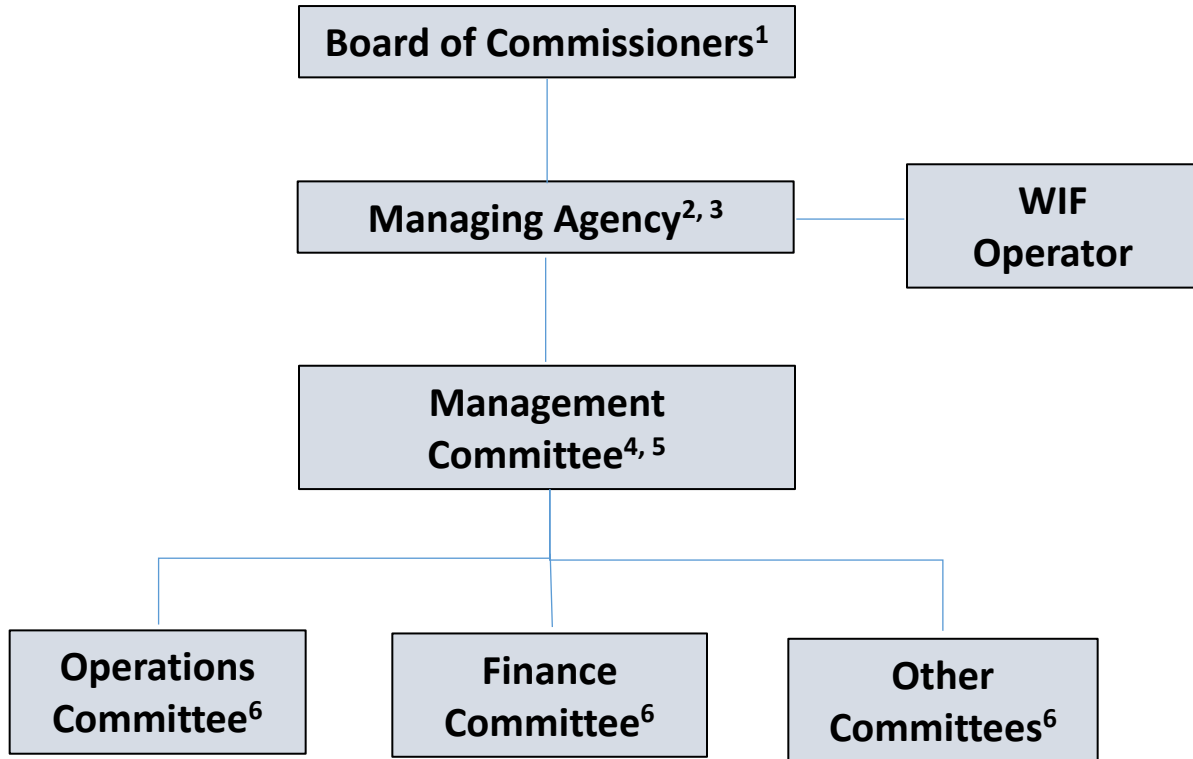

Notes:

1. Appointed by governing bodies of each Party
2. Provides its and Management Committee's recommendations to Board
3. Provides support to and consults with all committees
4. Provides recommendations to Managing Agency to be forwarded to the Board
5. Serve as liaisons to Parties' governing bodies
6. Provides recommendations to Management Committee

Exhibit 7
Willamette Intake Facilities
Managing Agency
Initial Management Plan

Description:

This Exhibit sets forth the Managing Agency Interim Term Plan under Section 5 of the Willamette Intake Facilities Intergovernmental Agreement (Agreement).

1. Designation of Interim Managing Agency

1.1. TVWD is designated as the Interim Managing Agency under Section 5 until June 30, 2032. In 2029, the Commission will complete a performance review of the Managing Agency and will decide whether to initiate the selection process under Section 6.1, Subsequent Appointment of Managing Agency, or continue with TVWD without engaging in the described process. TVWD will designate General Manager that will have primary responsibility for reporting to the Commission.

2. Duties of Interim Managing Agency

2.1. TVWD shall have all duties and powers of the Managing Agency under Section 6, except as provided in Paragraphs 3.0 and 4.0 of this Exhibit.

3. Interim Operations Management Until 2022

3.1. Wilsonville and TVWD have approved an operations contract extension with Veolia through June 30, 2022 for the Willamette River Water Treatment Plant. The scope of work for this contract includes operation of the Willamette Intake Facilities. Upon execution of this Agreement by the parties, the Commission delegates authority to Wilsonville, through its own forces or through the operations contract, to manage daily operations and operational coordination of the Intake Facilities to:

- 3.1.1. Assure delivery of water to the WRWTP for the benefit of Wilsonville and Sherwood; and
- 3.1.2. Assure effective coordination with the design and construction of improvements, modifications, and expansion of the Intake Facilities and connection to a new WWSS transmission pipeline.

3.2. Prior to expiration of this contract extension, the Parties will cooperate in conducting an evaluation of performance under the contract and will coordinate to identify planned activities of all Parties relating to the Intake Facilities during the period July 1, 2022 to June 30, 2026. Based on that coordination, the Management Committee will recommend to Wilsonville terms and activities that should be addressed in a contract extension or operations protocols for the period July 1, 2022 through June 30, 2026.

4. Interim Operations Management from 2022 to 2026

4.1. For the period of July 1, 2022 to June 30, 2026, the Commission delegates authority to Wilsonville, through its own forces or through an operations contract, to manage daily operations and operational coordination of the Intake Facilities. Thereafter, the Commission shall determine who will manage the operations of the Intake Facilities and may either delegate this responsibility to the Managing Agency or to a Party or contractor.

5. Wilsonville covenants that it will do the following during the Interim Operations Management periods:

- 5.1. Daily operations and operational coordination to supply water to the existing WRWTP;
- 5.2. Timely and cooperative coordination with TVWD (or its designee, Willamette Water Supply Program staff) in the construction of the expansion of the Intake Facilities and the WWSS transmission pipeline;
- 5.3. Timely and cooperative coordination with TVWD (or its designee, Willamette Water Supply Program staff) of Wilsonville/Sherwood operations and the startup and commissioning of the expansion of the Intake Facilities during calendar year 2025;
- 5.4. Best efforts to effect transition of all intake operations to the Commission and facilitate assumption of operational duties to the Party designated by the Board on or before June 30, 2026.

6. Repairs to Existing Intake Facility Assets Prior to June 30, 2026

- 6.1. Wilsonville has identified that there may be potential repairs required to the intake pipe, caisson, sparge system, and grout pipe joints in order to repair maintain and preserve the Intake Facilities. Any such repair costs (less any cost for sediment removal which shall only be paid by those actually drawing water through the Intake Facilities, currently Wilsonville and Sherwood), shall be shared by Wilsonville, TVWD, Sherwood, Hillsboro, Tigard and Beaverton in proportion to Intake Facilities Capacity ownership. Wilsonville will evaluate the condition of the Intake Facility when the sediment clean-out occurs, scheduled for Fiscal Year 2017-18. If the need for any repairs is identified, Wilsonville will work with the Willamette Water Supply Program to incorporate those repairs into the expansion of the Intake Facilities, managed by TVWD, to achieve construction coordination and cost savings. If Wilsonville discovers any repairs that it deems must be made before the expansion of the Intake Facilities is ready for construction, including any emergency repairs, Wilsonville will notify the Managing Agency about the repairs and may proceed independent of the expansion of the Intake Facilities. Wilsonville will follow all public contracting rules in making any such repairs and will invoice the Managing Agency the actual costs of any such required repairs. Wilsonville and TVWD will coordinate the Intake Facility expansion and any other Intake Facility repairs so that the making of the repairs and expansion of the Intake Facility will not interfere with or adversely impact the expansion of the Intake Facilities or the WRWTP.

7. Interim Fee

- 7.1. TVWD, as the initial Managing Agency, will prepare a work plan and associated cost estimate for the Fiscal Year 2017-18 budget for Commission administration responsibilities. Budgets for subsequent years will be proposed by TVWD and will be subject to review by the Parties and will require approval by the Board, as provided in this Agreement.
- 7.2. Wilsonville elects not to charge an Interim Operations Fee to the Commission.

Exhibit 8
Willamette Intake Facilities
Budget Calendar

Description: Annual Proposed Budget Submission and Calendar

The Board shall adopt a budget for its operations and capital improvements for each Fiscal Year. The Managing Agency shall annually prepare a budget for administration, operations, and capital improvements in coordination with the appropriate committees representing the Parties as described in Section 7 of this Agreement. The budget review process shall follow the following schedule listed below.

Budget Deliverable	Annual Submission Date	Party Receiving Budget
Preliminary capital improvement project list	December 15	Operations Committee
Preliminary budget	January 5	Operations and Finance Committees
Draft budget	February 15	Management Committee
Proposed budget	March 31	Board

The proposed budget for review shall be submitted with the proposed annual work plan, associated budget narratives, project descriptions, and budget summary spreadsheets for each level of Committee and Board review.

Exhibit 9
Willamette Intake Facilities
Interim Financial Procedures

Description:

The Willamette Intake Facilities Commission (Commission) is a joint venture of the cities of Beaverton, Hillsboro, Tigard, Sherwood, and Wilsonville and the Tualatin Valley Water District. The Commission owns and operates water intake facilities for the benefit of the Parties to the Willamette Intake Facilities (WIF) Agreement. This Exhibit establishes the interim financial procedures to be followed by the Commission as it undertakes its activities as described in Exhibit 7 to the WIF Agreement. The City of Wilsonville operates the current WIF facilities and those operations are not included within the interim financial procedures.

These interim financial procedures consist of three sections. Each is described below.

1. Elements of Financial Procedures:

a) Establishing Rates and Charges

This section outlines the methodology the Commission will use to set rates and charges to recover the cost of operating the Commission.

b) Accounting and Financial Reporting

This section outlines the accounting and financial procedures that the Commission and its managing agency will follow.

2. Establishing Rates and Charges:

a) Rate Setting Process

Each Party's proportionate share of the expenditures of the Commission, shall be estimated by the Commission, and set forth in the Commission's annual budget.

b) Quarterly Payments

Each Party shall make quarterly payments to the Commission for operations in accordance with the IGA.

i. *Commission Expenditures*

Each Party shall pay for its share of the Commission's expenditure quarterly based on the formulas described below.

ii. *Allocation of Expenditures for Administration*

Expenditures related to administration of the Commission will be allocated among the Parties using the following formula: Twenty-five percent of the expenditures of the Commission will be divided evenly among the Parties; and

the remaining 75 percent will be divided among the Parties according to each Party's percentage share of the Capacity Ownership in the WIF facilities.

- iii. *Allocation of Expenditures for Operations, Maintenance, and Repair***
Expenditures by the WIF for Operations, Maintenance, and Repair of the facilities shall be identified by the Operations and Finance Committees along with an allocation methodology. Operations, Maintenance, and Repair expenditures that are the result of use of the facilities will be allocated based on each Party's proportionate use of the WIF facilities. Operations, Maintenance, and Repair expenditures that are unrelated to use will be allocated based on each Party's proportionate ownership of the WIF facilities. If an expenditure serves multiple purposes, jointly, the Operations and Finance Committees shall divide expenditures into both use-based allocations and ownership-based allocations in a fair and equitable manner. If the matter cannot be resolved by the joint Operations and Finance Committees, the matter shall be referred to the Management Committee for resolution.
- iv. *Invoicing***
The Commission shall invoice the Parties for the prior quarter's expenditures within thirty days of the end of the preceding quarter. Payment is due to the Commission thirty days after receipt of the invoice.

3. Accounting and Financial Reporting:

a) Periodic Financial Reports

The Commission shall maintain an independent budget control procedure and provide budget reports at least quarterly to each of the Parties not later than 30 days after the end of each quarter. This report shall show expenditures and receipts by budget item for each transaction through the last working day of the preceding quarter.

b) Accounting Policies

i. *Fiscal Year*

The Commission shall operate on a fiscal year basis from July 1 through June 30 of the subsequent year.

ii. *Accounting Standards*

The Managing Agency shall use generally accepted accounting principles to account for the transactions of the Commission. The Commission shall be treated as an enterprise fund for accounting purposes and report its finances on an accrual basis.

iii. *Indirect Cost Allocations*

The Managing Agency shall maintain an indirect cost allocation plan that conforms to industry standards for allocating the indirect overhead costs of the entity. The Managing Agency shall submit the indirect cost allocation plan annually with the budget.

iv. *Working Capital*

The Managing Agency will provide working capital for the Commission by paying the Commission's bills when due and receiving payments from the Partners within 30 days after invoicing. The Managing Agency shall adopt accounting procedures to determine the cost of providing the Commission working capital and shall be entitled to charge the Parties a proportionate share of the cost of providing the working capital. The cost of providing the Commission's working capital shall be based on the forgone interest earnings the Managing Agency could have earned at its then-current rate of earnings on its portfolio of investments. Working capital, and the rate, will be listed separately on the invoices.

Exhibit 10
Willamette Intake Facilities
Lease Payment Formulas

Firm Lease Formula:

The lease payment for Willamette Intake Facilities capacity shall be determined by utilizing the depreciated replacement cost value of the asset amortized over the remaining book depreciation life of the asset at an interest rate equal to the Municipal Bond Index rate at the year of the lease payment, Engineering News Record (ENR) index rate, or a comparable index. The Commission may modify the method used to calculate lease payments by resolution of the Board. A firm lease rate example is shown in the Attachment 1 to this Exhibit.

Interruptible Lease Formula:

The interruptible lease payment for the Willamette Intake Facilities shall be 80 percent of the firm lease rate formula minus the daily rate amount that the capacity was withdrawn from the Lessee back to the Lessor. The interruptible lease shall have a minimum term of 12 months. The lease payment shall be calculated at the start of the lease term using 80 percent of the firm lease as determined by the firm lease formula. The interruptible lease cost shall be recalculated at the end of the lease term. If the Lessor notified the Commission that its interruptible capacity was not available for any portion of that lease year, the interruptible lease cost would be reduced by 1/365 of the cost for each day that it withdrew the interruptible capacity. If the Lessor agency did not exercise the right to withdraw capacity during the lease year, then full interruptible lease cost would apply.

Interruptible Lease Rate = 80% * (Firm Lease Rate for 1 year) – [(Number of Days Withdrawn/365 * (80% * Firm Lease Rate for 1 Year)]

Surplus Capacity Pool Formula:

The protocols for Surplus Capacity Pool payment for the Willamette Intake Facilities shall be determined using the firm lease rate formula calculated with a daily rate and multiplied by a factor of two. For each day that the Surplus Capacity Pool capacity was used, the Lessee of the pool will be required to pay that daily rate. The Surplus Capacity Pool capacity requests and payment procedures will be developed and determined by the Managing Agency.

Surplus Pool Daily Rate = (1/365) * Firm Lease Rate for 1 year * 2

Exhibit 10 - Attachment 1
Willamette Intake Facilities Commission
Firm Lease Payment Example

Assumptions:

Year of Construction		2000
Cost of Constuction	\$	19,683,536
Capacity		150 MGD
Useful Life		50 Years
First Year of Lease		2026
Municipal Bond Index (Year of Lease)		4.93%
ENR Cost Construction Index-Seattle (Month/Year Construction was Complete)		7,368.25
ENR Cost Construction Index-Seattle-December Prior to Mo/Year of Lease-Update for all assets		7,368.25

Lease Calculation:

Replacement Cost (Capacity*ENR CCI-Seattle Construction Complete/ENR CCI-Seattle-Dec prior to lease)	\$	19,683,536
Accumulated Depreciation (Replacement cost/Useful Life*(First Year of Lease-Year of Construction)		10,235,439
Depreciated Replacement Cost	\$	9,448,097
Lease Payment	\$	680,057
Annual Cost	\$	4,534 Per MGD

**EXHIBIT 10
ATTACHMENT 2
SAMPLE LEASE**

This Willamette Intake Facilities Lease (Agreement) is entered into this _____ day of _____, 20__ between _____, located in Washington County, Oregon (hereinafter “_____”), and _____, a _____ located in Washington County, Oregon.

Recital:

WHEREAS, the parties to this Agreement are members of the Willamette Intake Facilities Commission (Commission), an intergovernmental entity formed pursuant to ORS Chapter 190 by agreement dated _____, and amended at various and sundry times since, including the addition of new members;

WHEREAS, the parties of the Commission have into a Willamette Intake Facilities Agreement dated _____, 20__;

WHEREAS, the Willamette Intake Facilities Agreement, among other things, provides for a party to lease all or a portion of its interest in a component(s) of the Intake Facilities as defined therein, including water rights and supplemental water rights, to another party, upon such terms and conditions as approved by the Commission;

WHEREAS, the parties hereto have agreed that _____ will lease _____ to _____ upon the terms and conditions set forth herein and that the Commission has approved the terms and conditions as evidenced by signature below and being fully advised

NOW, THEREFORE, THE PARTIES AGREE AS FOLLOWS:

1. **Intake Facilities Capacity.** _____ agrees to provide _____, and _____ agrees to purchase, _____ million gallons per day in Willamette Intake Facilities capacity each fiscal year during the life of this Agreement, unless modified by other provisions of this Agreement, for an initial ___-year period beginning _____, through _____, subject to renewal, extension or termination on the terms and conditions as set forth in this Agreement. If a change in lease is anticipated because _____ (Lessor’s) demands have increased, the parties will negotiate the terms of such change.

2. **Connections, Measurement and Meters.** The Commission or the leasing Party as appropriate and necessary will provide and maintain meters, valves and controls, and measurement devices, in proper order for measurement of Intake Facilities capacity used and connections at the following locations:

Meters or measurement devices shall be tested and calibrated biennially by the Commission or an independent tester qualified to do such work. A copy of the test report shall be forwarded to the parties hereto.

3. **Rates.** _____ shall be billed monthly for the total leased Intake Facilities capacity under this Agreement, and payment shall be made within 30 days of billing. A late fee of 1.5 percent per month shall be assessed for any unpaid balance.

_____ will pay monthly to _____ for all leased asset capacity , at rates as described in Exhibit X of the Willamette Intake Facilities Agreement.

Inasmuch as _____ has contracted to lease an amount of capacity each year, _____ agrees to pay _____ the greater of: the amount calculated based on the actual volume of water passing through the meter(s) described above; or the amount calculated based on the minimum lease amount. This calculation will be done annually after the end of the year.

4. **Term.** This Agreement shall be for _____-years, commencing with execution of this Agreement and ending _____ years thereafter.

[ALTERNATIVE A]

_____ agrees to notify _____ in writing as soon as practicable if _____ wishes to extend the term of this Agreement, but not later than one year prior to the termination of this Agreement. The parties shall meet to determine if extension or renewal and the terms thereof is mutually agreeable.

[ALTERNATIVE B]

_____ shall have the right to renew this Agreement for _____ successive periods of _____ years, each by giving written notice thereof not less than one year prior to the expiration of this Agreement, whichever shall first occur. The terms and conditions of this Lease shall continue in any renewal term.

5. **Notices.** Notices shall be deemed sufficient if deposited in the United States mail, postage prepaid, to the following addresses:

6. **Severability.** In the event any provisions of this Agreement shall be held to be impossible, invalid or unenforceable, the remaining provisions shall be valid and binding upon the parties hereto. One or more waivers by either party of any provision, term, condition or covenant, shall not be construed by the other party as a waiver of subsequent breach of the same by the other party. Both parties have fully participated in negotiating and writing this Agreement; therefore, it

shall not be construed against the party preparing it, but shall be construed as if both parties have prepared it.

7. **Acts of God, Emergency, Etc.** Performance or delay in performance of the obligations stated in this Agreement shall be reasonably excused when performance or timely performance is impossible or impracticable because of the occurrence of unforeseeable events such as emergency, catastrophe, disaster, labor disputes, or acts of God.

8. **Disputes: Attorney's Fees.** If a dispute arises between the parties regarding breach of this Lease, the dispute resolution process in Section ___ of the Agreement shall be utilized.

9. **Full Agreement.** This document is the entire, final and complete agreement of the parties pertaining to _____ lease of Intake Facilities to _____, and supersedes and replaces all prior or existing written and oral agreements between the parties or their representatives.

10. **Service Reduction in Case of Emergency.** If a general emergency or water shortage requires restrictions on the delivery of raw water, general restrictions placed upon deliveries to _____ shall be determined by the Curtailment Plan.

By: _____

By: _____

APPROVED AS TO FORM AND
CONTENT

WILLAMETTE INTAKE FACILITIES
COMMISSION

By: _____

Exhibit 11
Willamette Intake Facilities
Intake Improvements Cost Allocation Summary
Preliminary Estimate - June 2017

Description:

The following is a summary of the cost estimate for the Intake Facilities improvements required to achieve a Capacity of 150 MGD. The cost estimates are based on preliminary design and will be refined as design progresses. Attachment 1 includes the preliminary design drawings and layout of the Intake Facilities.

Assumptions

1. Costs based on WWSP cost estimates presented to WGG on 5/25/17
2. Assumes total expanded capacity of intake is 150 MGD, including:

Feature	Capacity (MGD)
Existing Screen Capacity	70
Additional Screen Capacity resulting from expansion	80
Existing Hydraulic Capacity of intake pipe & caisson	120
Additional Hydraulic Capacity of intake pipe & caisson from expansion	30

3. Assumes permitting and mitigation costs = \$1.257 million (WWSP, 6/9/17)
4. Assumes screen cost for 150 MGD = \$4.65 million – includes intake screen replacement to 150 MGD, intake screen protection, and upgrades to air burst system (WWSP, 5/24/17)
5. Assumes seismic upgrade for the Intake Facilities = \$9.36 million – includes piles and jet grout for seismic stability of existing caisson structure (only); does not include seismic improvements for WWSS improvements (WWSP, 5/24/17)
6. Value of remaining useful life of existing screen = \$7,876 per MGD (Wilsonville, March 2017)

Anticipated Cost Allocations

Note: Costs and cost allocations are based on capacity shares and preliminary cost estimates as of current date and are subject to change. Final cost shares will be updated based on final capacity shares and actual costs for proposed improvements using cost allocation methodology as detailed below.

Partner	Capacity (MGD)	Capacity Share (%)	Cost Allocations (\$)			
			Permitting (1)	Screen & Air Burst	WIF Seismic Upgrades (9)	Total
Wilsonville	25.0	16.7%	\$ 75,000	\$ 50,000 (2)	-	\$ 125,000 (3)
TVWD (4,8)	59.1	39.4%	\$ 393,786	\$ 955,000 (5)	\$ 4,487,458	\$ 5,836,244
Sherwood (6)	9.7	6.5%	\$ 77,567	\$ 160,000 (7)	\$ 605,280	\$ 842,847
Tigard (8)	15.0	10.0%	\$ 189,674	\$ 930,160	\$ 1,138,949	\$ 2,258,783

Hillsboro (8)	36.2	24.1%	\$ 457,748	\$ 2,244,786	\$ 2,748,663	\$ 5,451,197
Beaverton (8)	5.0	3.3%	\$ 63,225	\$ 310,053	\$ 379,650	\$ 752,928
Total	150.0	100.0%	\$ 1,257,000	\$ 4,650,000	\$ 9,360,000	\$ 15,267,000

Footnotes for Cost Allocation Methodology

Cost allocations are generally based on proportionate ownership shares subject to additional terms and conditions as noted below.

1. Permitting cost allocation assumes 50% of costs applied to new capacity (80 MGD) and 50% of costs applied to total capacity (150 MGD).
2. Wilsonville receives full credit equal to remaining undepreciated asset value of 20 MGD share of existing screen.
3. Wilsonville total cost cap for permitting, screen, air burst & seismic = \$125,000.
4. TVWD capacity share includes 56.5 MGD for demand and 2.6 MGD of capacity not allocated to other partners.
5. TVWD receives partial credit for remaining undepreciated asset value of 45 MGD share of existing screen.
6. Sherwood does not contribute toward Wilsonville’s cost shares in excess of Wilsonville cost caps for permitting, screen, and seismic improvements.
7. Sherwood receives partial credit for remaining undepreciated asset value of 5 MGD share of existing screen.
8. TVWD, Tigard, Hillsboro and Beaverton costs include allocation, proportionate to capacity share, for Wilsonville’s cost shares for permitting, screen, and seismic improvements in excess of Wilsonville cost caps.
9. Improvements for seismic stability of existing caisson structure and intake pipe only; does not include seismic improvements for WWSS improvements. Wilsonville cost share for seismic improvements = \$0. TVWD, Tigard, Hillsboro and Beaverton - but not Sherwood - pay Wilsonville’s cost share for seismic improvements.

Exhibit 12
Willamette Intake Facilities
Insurance Requirements and Limits

Description:

The following insurance requirements and limits are necessary for the operations of the Willamette Intake Facilities (Intake Facilities) and shall be purchased and maintained at all times. The requirements will be reviewed and approved by the Board annually, and modified when necessary.

1. Insurance Requirements

- (a) The Managing Agency shall obtain and maintain at all times appropriate insurance coverage for the Intake Facilities on behalf of the Commission based on exposure. Where applicable, the insurance limit shall meet or exceed the corresponding monetary limit of the Oregon Tort Claims Act. For all other insurance, the insurance limits shall meet or exceed the corresponding limit or obligation established for a special government body under Oregon law.
- (b) The Managing Agency shall recommend the purchase of all necessary insurance to protect the interests of the Intake Facilities and the Commission.
- (c) The Board shall review and approve insurance coverage, limits and deductibles proposed by the Managing Agency.
- (d) The Commission, its members, officers, boards, agents and employees will be listed as additional insureds on all policies purchased by the Managing Agency for the Intake Facilities, and be listed on insurance policies required of the Commission of their contractors and consultants.

2. Summary Insurance Requirements and Limits:

a) Property

To include loss or damage to all types of property owned by the Commission due to perils such as fire, wind, theft, vandalism, malicious mischief, earthquake and flood, for the full insurable replacement-cost basis. (For earthquake and flood, a sublimit typical of the industry standard). Property coverage shall also include machinery breakdown coverage.

b) Commercial General Liability

To include all major coverage including bodily injury, personal injury, property damage and wrongful acts. Coverage shall be provided for all XCU (explosion, collapse and all underground) hazards and shall be in the amount not less than **\$2,000,000** per occurrence and **\$4,000,000** general aggregate.

c) Automobile Liability

To include all owned, hired and non-owned vehicles of a combined single limit per occurrence shall not be less than **\$2,000,000**.

d) Workers' Compensation and Employers' Liability

Workers' compensation coverage sufficient to meet statutory liability limits and Employers' Liability of **\$1,000,000** for each accident, **\$1,000,000** for each bodily injury/disease and **\$1,000,000** for aggregate bodily injury/disease.

e) Fidelity bond or Crime

A fidelity bond or equivalent crime coverage in the amount not less than **\$500,000**.

f) Directors and Officers

For the protection of all directors and officers of the Commission in the amount of not less than **\$1,000,000**.

g) Pollution Liability

The Board may require the purchase of pollution liability coverage for any significant construction projects on the Intake Facilities or may require contractors to obtain pollution liability coverage for the Intake Facilities construction projects. Contractors' policy shall name the Commission as an additional insured.

Exhibit 13

Existing Agreements

Description:

The following is a list of existing agreements between some or all of the Parties that affect or are affected by the Intake Facilities that are the subject of this Agreement. These related agreements are not superseded by this Agreement unless agreed to by the parties to those agreements.

- 1) *Agreement Regarding Water Treatment Plant Design, Construction, Operation and Property Ownership* (“2000 Master Agreement”), dated July 6, 2000 and entered into by Wilsonville and TVWD
- 2) *The Accord Agreement* (“Accord”), dated June 19, 2001 and entered into by Wilsonville and TVWD
- 3) *First Amendment to Agreement Regarding Water Treatment Plant Design, Construction, Operation, and Property Ownership*, dated _____, 2018, entered into by TVWD and Wilsonville;
- 4) *Operation and Maintenance Contract with Veolia Water North America-West LLC*, dated July 1, 2017, as amended, entered into by TVWD and Wilsonville;
- 5) *First Restated Intergovernmental Cooperative Agreement Continuing the Willamette River Water Coalition* (“WRWC Agreement”), dated October 15, 2008 and entered into by TVWD, Sherwood, Tigard, and Tualatin
- 6) *Sherwood and Tualatin Valley Water District Willamette River Water Treatment Plant Agreement* (“Sherwood TVWD WRWTP Agreement”), dated December 27, 2006 and entered into by TVWD and Sherwood
- 7) *Agreement for Design and Construction of the Willamette Water Supply Program* (“WWSP Agreement”), dated June 16, 2015 and entered into by TVWD and Hillsboro
- 8) *Agreement(s) for Transfer, Purchase and Sale of Intake Facilities*, dated _____, 2018 and separate agreements entered into by TVWD and Beaverton, TVWD and Hillsboro, TVWD and Sherwood, TVWD and Tigard
- 9) *City of Wilsonville and Tualatin Valley Water District Willamette Water Supply System Intake Facility Agreement*, dated _____, 2018 and entered into by Wilsonville and TVWD

- 10) *Ground Lease for the Raw Water Pipeline*, dated _____, 2018, entered into by TVWD, Wilsonville, and Hillsboro.
- 11) *Easement for Raw Water Pipe*, dated _____, 2018, entered into by TVWD, Wilsonville, and Hillsboro.
- 12) *Intake and Pipeline Easement No. 22670-EA*, dated July 13, 2000 and granted by the State of Oregon Division of State Lands to the City of Wilsonville.